

# UNIQUE®

50L

## SOLAR POWERED FRIDGE/FREEZER

---

50L / 1.8 cu. ft.  
UGP-50L1



---

OWNER'S GUIDE

# TABLE OF CONTENTS

03	Important safety notes
07	Installation
08	DC power connection
11	Operation
15	Energy saving tips
16	Troubleshooting
18	Appliance information
18	Notes
19	Contact us
19	Limited warranty

## IMPORTANT SAFETY NOTES

**IMPORTANT: Allow the freezer to rest in its normal operating position for 2 hours before turning it on for the first time.**

**After transit where the fridge/freezer is on its side or back, ensure fridge/freezer is in a level, upright position for 12 hours to allow compressor fluids to redistribute evenly before use.**

**Congratulations!** You have purchased one of the most efficient refrigeration products available on the market today. The Unique chest freezer is designed to provide years of efficient trouble-free operation. The design is optimized for energy savings with an efficient DC compressor, thick insulation, and a chest style configuration.

Before using the appliance, read through this manual carefully including all the information on safety, installation, operation, and cleaning. These guidelines do not cover every possible condition or situation that may occur. Be safe using common sense and caution when installing, operating and cleaning this appliance. If you are unsure about any of these instructions or warnings, contact your local product dealer or Unique Off-Grid Appliances for assistance.

## IMPORTANT SAFETY NOTES continued

- To allow the interior to cool down properly, run the fridge/freezer for at least 4 hours empty before adding food.
- This fridge/freezer is designed to operate on 12 or 24 volts DC ONLY. **DO NOT CONNECT THIS FRIDGE/FREEZER TO AN AC (alternating current) POWER SOURCE.**
- This fridge/freezer is designed for domestic use only! It is intended for the storage of edible/consumable food and drinks. It is not intended for commercial or industrial use.
- Never use excessive force on the handle to open the lid.
- If the room/ambient temperature approaches the fridge/freezer's operating temperature, the fridge/freezer may not function correctly. If the room/ambient temperature exceeds 100°F (38°C) the fridge/freezer may not function correctly.
- A battery-powered fridge/freezer has a lower cooling capacity than typical AC-powered appliances. Because the compressor is small, the fridge/freezer runs more efficiently but lacks the ability to cool larger warm loads as quickly as typical AC-powered appliances.

# IMPORTANT SAFETY NOTES continued

These warnings are provided in the interests of your safety. Please ensure that you understand them all before installing or using this fridge/freezer. Your safety is of paramount importance. If you are unsure about any of these meanings or warnings, contact your local product dealer or Unique Off-Grid Appliances for assistance.

## **PRIOR TO INSTALLATION:**

At delivery, please check that the fridge/freezer is complete and has not been damaged during transport. It is not advised to connect an appliance that has been damaged, especially damage to the electrical supply cable or refrigerant circuit. In the event of damage please contact your local product dealer or Unique Off-Grid Appliances for assistance.

## **GENERAL SAFETY**

- Before cleaning or repositioning the fridge/freezer, always disconnect from the electrical power supply.
- Service the fridge/freezer only if you are a trained or authorized refrigeration technician.
- This appliance contains refrigerant R-134a and a polyolester compressor oil in its refrigerant circuit. Take utmost care when handling your fridge/freezer so as to not cause damage to the refrigerant circuit with consequent possible leakage.
- Do not use other electrical appliances (such as ice cream makers) inside of the refrigerating appliance.

## **CHILD SAFETY**

- **Do not allow children to play in, on or around the fridge/freezer. It is not a toy. THERE IS A DANGER OF SUFFOCATION IF A CHILD BECOMES TRAPPED INSIDE.**
- When the appliance is not in use, secure or remove the lid to prevent children from playing inside the cabinet.
- **DANGER OF SUFFOCATION** - Keep children away from all packaging material.

## **INSTALLATION**

- This appliance is heavy. Care should be taken when moving it.
- This appliance operates on 12 or 24 Volts DC (Direct Current) only!
- Under no circumstances should this appliance be directly connected to an AC (Alternating Current) power source.
- Be sure that the appliance does not stand on the electrical sup-

## IMPORTANT SAFETY NOTES continued

ply cable. Also, be sure the electrical cable is not squeezed or bent when the appliance is being installed or moved.

- Installation work and adjustments on the appliance must be carried out by qualified personnel only. Work performed by persons with inadequate technical knowledge may adversely effect the performance of the appliance, causing damage to the equipment, and void the warranty.
- It is dangerous to make alterations or attempt to modify this product in any way. Product alterations will void the warranty.

### DURING USE

- This appliance is designed for domestic use only, specifically for the storage of food and drinks. This appliance is not designed for commercial or industrial use.
- Do not store any containers with flammable vapors or liquids in or around the appliance, such as organic solvents, spray cans, gas cans, etc. Danger of explosion!

### CLEANING

- Before cleaning always turn the fridge/freezer off and disconnect it from the electrical power supply.
- Allow inside of fridge/freezer to fully thaw, then wash the inside and outside of the appliance with luke warm water and a mild soap or detergent. Abrasive or corrosive cleaning agents, steel wool, scouring sponges, or chemical cleaning agents should not be used under any circumstances.

### SERVICING

- This product should be serviced by an authorized technician and only genuine spare parts should be used.
- Under no circumstances should you attempt to repair the appliance yourself. Repairs carried out by inexperienced persons may cause injury or serious malfunctioning of the appliance. **Unauthorized work may void the warranty.**

### DISPOSING OF THE APPLIANCE

- When disposing of your fridge/freezer, use an authorized disposal site. The refrigerant must be completely drained and collected by an authorized technician for recycling prior to disposal. Check with your local Environmental Agency for recommendations on recycling this appliance in your area. Remove the electrical connection wiring and also ensure that the lid is removed to prevent children from being trapped inside - **DANGER OF SUFFOCATION!**

# INSTALLATION

## UNPACKING AND CLEANING

Remove all packaging and securing tapes from the appliance.

To avoid injury and causing damage to the appliance, be extremely cautious when using sharp or pointed tools to complete this task. Keep children away from the packaging material - DANGER OF SUFFOCATION! Wash the inside and outside of the appliance with luke warm water and a mild soap or detergent. Abrasive or corrosive cleaning agents, steel wool, scouring sponges, or chemical cleaning agents **should not** be used under any circumstances. A sponge, soft brush or towel is recommended. After cleaning, thoroughly rinse and dry. You may want to leave the lid open allowing the compartment to ventilate for 20-30 minutes to get rid of residual odors. Check with your local Environmental Agency for recommendations on recycling packaging materials in your area.

## POSITIONING THE APPLIANCE

The area in which the fridge/freezer is to be installed must be relatively cool, dry, and suitably ventilated. The area must be protected against any inclement weather (rain, snow) and excessive surface dust. To ensure proper function, the appliance must be placed horizontally on a flat, firm, and stable surface resting level on all four supports. The floor must be strong enough to support a fully loaded cabinet. Use wood or metal shims to level the fridge/freezer if necessary.

Do not place the fridge/freezer close to heat sources (heater, stove, boiler, chimney, etc.), and avoid prolonged exposure to direct sunlight. This appliance uses the exterior walls to transfer heat from the inside of the cabinet. Ensure that there is adequate space between the fridge/freezer and neighboring walls or large objects. A minimum spacing of 3 inches (7.5 cm) is highly recommended. This will provide sufficient airflow around the appliance resulting in more efficient operation and longer appliance lifetime. Always keep the air vent openings of the compressor housing cover free from dust and obstructions.

## DC POWER CONNECTION

**IMPORTANT:** Allow the freezer to rest in its normal operating position for 2 hours before turning it on for the first time.

After transit where the fridge/freezer is on its side or back, ensure fridge/freezer is in a level, upright position for 12 hours to allow compressor fluids to redistribute evenly before use.

**THIS FRIDGE/FREEZER MUST NEVER BE CONNECTED DIRECTLY TO ANY AC (alternating current) POWER SOURCE!**

THE FRIDGE/FREEZER MUST ONLY BE CONNECTED TO A 12V OR 24V DC POWER SOURCE, SUCH AS A BATTERY OR CHARGE CONTROLLER.

THE FRIDGE/FREEZER WILL AUTOMATICALLY OPERATE ON EITHER 12V OR 24V DC. THE USER DOES NOT NEED TO MAKE ANY ADJUSTMENT.

**ATTENTION:** Polarity is important in wiring this DC appliance. Be sure that the positive terminal of the battery or charge controller coincides with the positive wire to the compressor, and the negative terminal of the battery or charge controller coincides with the negative wire to the compressor. The leads should be connected using cable shoes and screwed connections. Joined leads should be avoided.

**+ to + and - to -**

**positive to positive / negative to negative**

# DC POWER CONNECTION continued

## ELECTRICAL DIAGRAM

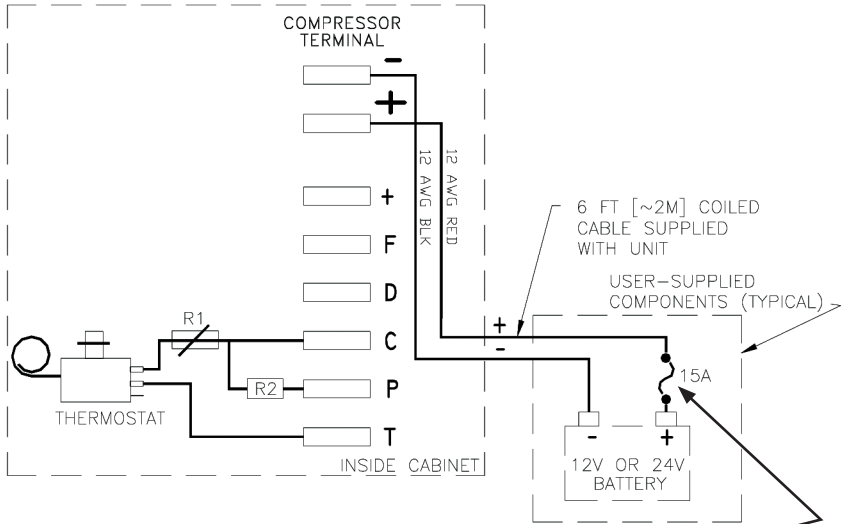

### USER (CUSTOMER) SUPPLIED COMPONENTS

#### Fuse

A fuse is recommended in order to protect the wiring. A standard automobile fuse is recommended and the fuse should be wired to the positive (“+”) side of the system close to the positive battery terminal. **For 12V operation, use a 15A fuse, and for 24V operation use a 7.5A fuse.**

OPERATING VOLTAGE	FUSE
12 V	15 A
24 V	7.5 A

## DC POWER CONNECTION continued

### ATTENTION

If a longer connection cable is necessary, the cable cross section (or gauge) must be equal to or greater than the cable sizes recommended on the following table. Be careful that the input voltage at the appliance does not drop below the cut-out voltage of the compressor.

CABLE SIZE		12V CABLE LENGTH		24V CABLE LENGTH	
AREA	AWG				
mm <sup>2</sup> /inch	Gauge	m	ft	m	ft
2.5 / <sup>3</sup> / <sub>32</sub> "	12	2.5	8	5	16
4 / <sup>5</sup> / <sub>32</sub> "	12	4	13	8	26
6 / <sup>15</sup> / <sub>64</sub> "	10	6	19.5	12	39
10 / <sup>25</sup> / <sub>64</sub> "	8	10	32.8	20	65.6

### LOW VOLTAGE DISCONNECT

The compressor electronics includes a low voltage disconnect feature. If the input voltage to the appliance falls below 9.6V (in 12 V mode) or 21.3V (in 24 V mode), the compressor will shut-off. Once the voltage increases above 10.9V (in 12V mode) or 22.6V (in 24V mode), the compressor will resume normal operation.

This feature is designed to protect the system battery from experiencing too low a depth of discharge.

	12 V OPERATION	24 V OPERATION
CUT-IN	9.6 V	21.3 V
CUT-OUT	10.9 V	22.7 V

# OPERATION

**Your Unique fridge/freezer, like any battery-powered refrigerating appliance, requires different care than appliances plugged into an electric utility. Prudent operation is the key to extended service.**

## STARTING THE FRIDGE/FREEZER

After the fridge/freezer has been properly connected to the 12 or 24 VDC power source, the compressor will automatically turn on and the cabinet will begin cooling. Allow the cabinet to cool for at least 4 hours prior to adding foodstuff.

## TEMPERATURE CONTROL

The temperature within the fridge/freezer is controlled by the thermostat situated on the lower front of the cabinet. When you first start the fridge/freezer we suggest that you turn the thermostat to a medium setting (3). The correct internal temperature setting can be found by measuring the temperature of the central or middle portion in the appliance.

**0 = Refrigerator setting**

**1-5 = Freezer settings**



NORMAL OPERATING TEMPERATURE		
	INTERNAL TEMP. (°F)	INTERNAL TEMP. (°C)
Setting = 0 (warmest)	38°F	3°C
Setting = 5 (coldest)	0°F	-18°C

The fridge/freezer will run a few degrees colder at high elevations.

## **OPERATION** continued

### **ADJUSTMENTS**

As the ambient temperature changes with the season, it may be necessary to adjust the thermostat to achieve the proper internal temperature. If the room/ambient temperature approaches the appliance's internal operating temperature, the appliance will not function as it should. The appliance will tend to run colder during these conditions and it may be necessary to turn the thermostat to a warmer setting (towards the 'min'). If the room/ambient temperature exceeds 100 °F (38 °C), the appliance will not function as it should. The appliance will tend to run warmer and it may be necessary to turn the thermostat to a colder setting (towards the 'MAX' setting).

### **OPENING AND CLOSING THE LID**

The lid is fitted with a uniform sealing strip to prevent warm air and moisture from entering the appliance compartment. Be sure that the lid and the lid seal are free from obstructions and form a complete seal around the rim of the cabinet. Overfilling and/or unlevel installation of the appliance will prevent a good seal.

It might be hard to open the lid immediately after the lid is closed. This is due to air contraction in the cabinet. This pressure difference will equalize in a few seconds.

### **LOADING THE FRIDGE/FREEZER**

**Do not over fill the appliance more than ½ in. (1.25 cm) below the edge of the casing.**

A battery-powered refrigeration appliance has a cooling capacity lower than typical AC appliances. Because the compressor is small, the appliance runs more efficiently but cools warm or room temperature food at a slower rate than an AC appliance.

When adding unfrozen food to the freezer for the first time, fill the freezer only 1/3 full and wait until that food is sufficiently frozen before adding more. It will also help to cool food more quickly if the food is packaged in smaller containers rather than large ones. Food packages more than 2 inches thick will cool slowly. Avoid placing warm food in contact with cold food.

### **NORMAL OPERATING SOUNDS**

- You may hear faint gurgling or bubbling sounds when the refrigerant is being pumped through the refrigerant coils.
- When the compressor is on, the refrigerant is being pumped through the appliance and you will hear a whirring or pulsing sound from the compressor.
- A thermostat controls the compressor and you may hear a 'click' when the thermostat cuts in and out.

## **OPERATION** continued

### **DEFROSTING**

Before cleaning or repositioning the fridge/freezer, you must **DISCONNECT** the appliance from the electrical power supply.

### **DEFROSTING THE FREEZER**

The fridge/freezer compartment will become progressively covered with frost. This should be removed periodically with a plastic scraper. However, when the ice becomes very thick on the interior walls, complete defrosting should be carried out. Perform this operation when the appliance is empty and disconnected from the power supply.

**NEVER USE SHARP METAL TOOLS TO SCRAPE OR CHIP OFF FROST FROM THE INTERIOR COMPARTMENT AS THIS COULD DAMAGE THE APPLIANCE BEYOND REPAIR. DO NOT USE HEAT SOURCES SUCH AS ELECTRIC OR GAS HEATERS TO COMPLETE THE DEFROST PROCESS.**

#### **To perform a complete defrosting:**

1. Disconnect the appliance from the electrical supply.
2. Remove any stored food and store in coolers, or wrap in several layers of newspaper and store in a cool place.
3. Leave the lid open.
4. Remove the plug from the defrost water drain located in the bottom interior of the cabinet.
5. To accelerate the defrosting process, place a bowl of hot (not boiling) water inside of the appliance and close the lid.
6. The defrost water can be collected by attaching a hose to the drainage port located at the back left of the cabinet and draining the water into a bucket.
7. When defrosting is complete, wash and dry the interior thoroughly. Be sure to replace the plug on the defrost water drain.
8. Reconnect the appliance to the electrical supply and leave running (while empty) for at least 2 hours allowing the interior to cool sufficiently.
9. Reload the fridge/freezer with the previously removed food.

**ATTENTION: Partial thawing of frozen food during defrosting may shorten its safe storage life-span.**

# **OPERATION** continued

## **CLEANING**

### **Internal Cleaning**

Wash the inside of the appliance with luke warm water and a mild soap. Never use abrasive or corrosive cleaning agents, steel wool, scouring sponges, chemical cleaning agents, or highly perfumed cleaning products to clean the interior as these will damage the surface and leave behind a strong odor. A sponge, towel, or soft brush is recommended. Washing with a mixture of two tablespoons (30ml) of baking soda to 1 quart (1.14L) warm water. After cleaning, wipe all surfaces with a soft cloth and clean water to rinse, and allow the fridge/freezer to dry.

### **External Cleaning**

Wash the outside of the cabinet with warm water and a mild soap or detergent.

Do not use abrasive or corrosive cleaning agents, chemical cleaning agents, steel wool or scouring sponges to clean the fridge/freezer as it may cause damage to the surfaces.

## ENERGY SAVING TIPS

- Do not install the fridge/freezer close to sources of heat, such as a stove, boiler, heater, chimney, etc, and avoid exposure of the appliance to direct sunlight.
- Locate the appliance in a cool well-ventilated room and make sure that the air vents of the compressor housing cover are not obstructed. Also allow adequate spacing around the cabinet for air circulation (3" or 7.5cm)
- Avoid unnecessary frosting in the cabinet by packing all food and liquids in airtight packages or containers.
- Always keep food stored in tightly sealed packaging or containers, and allow some space for air to circulate around each item.
- Avoid keeping the lid open for extended periods of time or opening the lid too frequently as warm air will enter the cabinet and cause the compressor to run unnecessarily often.
- Ensure there are no obstructions preventing the lid from closing properly and forming a tight seal.

# TROUBLESHOOTING

Before contacting a service technician, your local product dealer or Unique Off-Grid Appliances, please check the following points. If you contact a technician to repair a fault listed below, or to repair a fault caused by misuse, abuse, or faulty installation, a charge will be made even if the appliance is under warranty.

PROBLEM	SOLUTION
Appliance is connected to power, but does not operate	<ul style="list-style-type: none"> <li>• Check if 12V or 24V DC is present at the appliance. If not, check all connections and the system battery voltage.</li> <li>• Check that the polarity is correct: positive (+) is connected to positive (+), and negative (-) is connected to negative (-).</li> <li>• Check the fuse. If blown, replace with a new one (see page 9 for details).</li> <li>• The primary problem with a non-functioning appliance is due to a voltage drop to the compressor, which causes the unit to fail to start due to “low voltage”. Typically a connection is not as tight as it should be, or the wire size to the compressor is too small. The low voltage problem occurs instantly at start-up and can be difficult to detect with a volt meter because it happens so quickly (&lt;100ms)</li> </ul>
Appliance is operating, but the interior (cabinet) is not cold	<ul style="list-style-type: none"> <li>• Allow the appliance at least 4 hrs to cool down once turned on.</li> <li>• Check that the thermostat control knob is turned to the correct setting relevant to the room/ambient temperatures.</li> <li>• Check that the room/ambient temperature is not approaching the internal operating temperature and does not exceed to 100° F (38° C).</li> <li>• Has too much warm food been added to the fridge/freezer recently? If so, it will take some time for the cooler to return to temperature.</li> <li>• Does the cabinet have adequate ventilation around the side walls, allowing it to transfer heat properly? (See Installation section)</li> </ul>
The lid will not open	<ul style="list-style-type: none"> <li>• Has the lid just been opened? If so, leave the appliance closed for a few minutes to allow the air pressure to equalize and try again.</li> </ul>

## TROUBLESHOOTING continued

Excessive frost and ice has built up	<ul style="list-style-type: none"><li>• Is the weather hot and humid? If so, this will increase the rate of frost build-up in the cabinet.</li><li>• Ensure that stored food is properly packaged.</li><li>• Check that the lid is closed and has a good seal, and that nothing is preventing the lid from closing properly.</li><li>• Large quantities of food have recently been placed in the cabinet, and/or the lid is frequently opened.</li><li>• Ensure that proper care and maintenance of the appliance has been performed (cleaning, defrosting, etc...)</li></ul>
Noise	<ul style="list-style-type: none"><li>• Refer to “Normal Operating Sounds” (page 12)</li></ul>

### CUSTOMER RESPONSIBILITIES

The following items are the responsibility of the customer and are not covered by the warranty:

- Proper care and use of the appliance as described in this manual.
- Damage to the interior or exterior finish or components after delivery.
- Proper power supply, fuse, wiring, and connections.
- Service required as a result of alteration, misuse, abuse, flooding, fire, lightning, or other acts of God.
- Replacement of light bulbs.



# UNIQUE<sup>®</sup>

## CONTACT US

For questions related to the operation, safety or the purchase of your fridge/freezer, please contact your dealer for more information. For general information, contact our customer service department:

- Toll-free: 1-877-427-2266 or 1-905-827-6154 (available during regular business hours, 8:30 am to 4:30 pm, EST).
- Email: [info@UniqueOffGrid.com](mailto:info@UniqueOffGrid.com)

Please visit our website for more quality off-grid products:  
[www.uniqueoffgrid.com](http://www.uniqueoffgrid.com)

Unique Gas Products Ltd., 2245 Wyecroft Road, Oakville, Ontario, Canada, L6L 5L7

## 50L SOLAR POWERED FRIDGE/FREEZER 1 YEAR LIMITED WARRANTY

**Unique Gas Products Ltd.**, warrants that this portable fridge/freezer is free from defects in material and workmanship under normal usage and service under the following terms:

1. This Warranty is made only to the first purchaser (“original purchaser”) who acquires this fridge/freezer for his/her own use and will be honored by **Unique Gas Products Ltd.** and by the Seller.
2. Any part of this fridge/freezer returned to the Seller or **Unique Gas Products Ltd.**, which upon examination is determined by them to have been defective in material or workmanship, will at their option be either repaired or replaced under this warranty, within 14 days from date of return to **Unique Gas Products Ltd.**, without charge for materials/parts.
3. The obligation to repair or replace defective parts will apply only to parts returned within one year of the date of purchase and will constitute the Sellers sole obligation under this Warranty.

The Seller will have no obligation under this warranty with respect to conditions unrelated to the material or workmanship of this fridge/freezer. Such unrelated conditions include without limitation:

- a) damage to any part of this fridge/freezer caused by misuse, neglect of service or any alteration thereof.
- b) use of this product for any purpose other than its Intended use.

This Unique fridge/freezer must be maintained regularly as outlined in the Owner’s Manual. **Unique Gas Products Ltd.** and the seller will not be liable for direct or indirect loss of foods caused by failure in operation. In case of failure, the owner must provide proof of purchase, model, and serial number to the seller or **Unique Gas Products Ltd.**

Please fill out warranty card within 30 days and mail back to Unique for warranty coverage.

**UNIQUE<sup>®</sup>**

© 2015 Unique Gas Products Ltd., 2245 Wyecroft Road, Oakville, Ontario, Canada,  
L6L 5L7  
[www.uniqueoffgrid.com](http://www.uniqueoffgrid.com)