



# Solar Industrial Line USER'S GUIDE



# Congratulations

on your purchase from Trojan Battery Company, the manufacturer of the world's most trusted deep-cycle batteries. The battery you purchased was engineered by Trojan to deliver superior power, performance, durability and reliability for use in a broad range of demanding applications.

If you have any questions concerning safety precautions or for any assistance in installing or using the batteries in your system, contact Trojan Battery Company's technical support engineers at the following numbers:



**TECHNICAL SUPPORT**

800-423-6569 Ext. 3045 or +1-562-236-3045

[www.trojanbattery.com](http://www.trojanbattery.com)

# The Solar Industrial Line User's Guide

was created by Trojan's application engineers and contains vital information regarding proper care and maintenance of your new Solar Industrial batteries. The guide includes information about safety instructions, installation considerations, and other valuable topics to help you install, operate and maintain your Solar Industrial batteries. Please read through this guide carefully and completely before using your batteries. It will help you achieve optimum performance and long life from your new investment.



To address the impact of Partial State of Charge (PSOC) on deep-cycle batteries in renewable energy (RE), inverter and telecom backup applications, Trojan Battery has now included Smart Carbon™, an intelligent solution to PSOC, as a standard feature in its Solar Industrial flooded battery lines.

# Contents

<b>01</b>	<b>Getting Started</b> . . . . .	<b>5</b>	<b>06</b>	<b>Battery Maintenance</b> . . . . .	<b>20</b>
	<b>a.</b> Safety Instructions . . . . .	5		<b>a.</b> Preventative Maintenance . . . . .	21
	<b>b.</b> Equipment Needed . . . . .	6		<b>b.</b> Standard Cleaning . . . . .	22
	<b>c.</b> Inspection . . . . .	6		<b>c.</b> Terminal and Connector Cleaning . . . . .	22
	<b>d.</b> What to Expect from your Trojan Battery . . . . .	7	<b>07</b>	<b>Watering</b> . . . . .	<b>22</b>
<b>02</b>	<b>General Safety Instructions</b> . . . . .	<b>9</b>	<b>08</b>	<b>Charging and Storage</b> . . . . .	<b>25</b>
	<b>a.</b> Important Electrical Safety Instructions . . . . .	9		<b>a.</b> Charging . . . . .	25
	<b>b.</b> Electrical Shocks and Burns . . . . .	10		<b>b.</b> Storage . . . . .	29
	<b>c.</b> Grounded and Ungrounded Batteries . . . . .	11	<b>09</b>	<b>Troubleshooting</b> . . . . .	<b>31</b>
<b>03</b>	<b>Installation Considerations</b> . . . . .	<b>12</b>		<b>a.</b> Specific Gravity Testing . . . . .	31
<b>04</b>	<b>Battery Connections</b> . . . . .	<b>14</b>		<b>b.</b> On-Charge Voltage Testing . . . . .	33
	<b>a.</b> Terminal Connections . . . . .	14		<b>c.</b> Open Circuit Voltage Testing . . . . .	33
	<b>b.</b> Cable Size . . . . .	14	<b>10</b>	<b>Battery Recycling</b> . . . . .	<b>34</b>
	<b>c.</b> Torque Values . . . . .	15	<b>11</b>	<b>Warranty Information</b> . . . . .	<b>35</b>
	<b>d.</b> Cable Installation Instructions . . . . .	15	<b>12</b>	<b>Battery Maintenance Log Sheet</b> . . . . .	<b>35</b>
	<b>e.</b> Terminal Protection Installation . . . . .	17	<b>13</b>	<b>Glossary of Terms</b> . . . . .	<b>36</b>
<b>05</b>	<b>Connecting Batteries to Increase Capacity</b> . 18		<b>14</b>	<b>Battery Acronyms</b> . . . . .	<b>44</b>
	<b>a.</b> Series vs. Parallel Connections . . . . .	18			
	<b>b.</b> Battery Orientation . . . . .	20			

# 01 Getting Started

## a. Safety Instructions

Since batteries deliver large amounts of power that can cause injury and even death, observing safety rules is of paramount importance. For your safety and the safety of those around you, please observe the following checklist when working on or around batteries.

Always	Never
<b>Always charge batteries in well-ventilated areas</b>	<b>Never charge a flooded battery without securing vent caps on the cells</b>
Always wear protective clothing, gloves, and safety goggles	Never smoke near batteries
Always use insulated tools when working on batteries	Never wear jewelry or other metal objects when working on or around batteries
Always check connections for proper torque	Never make direct contact with the electrolyte (sulfuric acid). If this occurs, flush with large amounts of water.
Always keep sparks and flames away from batteries	Never place objects on top of batteries
Always use short cables of appropriate size to minimize voltage drop	Never add acid to a battery
Always ensure plates are covered in water before charging	Never charge a frozen battery
Always make sure charger is set for the appropriate battery type (flooded, AGM or gel)	Never charge a battery when the temperature is above 122°F (50°C)
Always charge batteries before installing	Never store batteries unless they are fully charged
Always neutralize small spills with baking soda and water. For large spills, contact the appropriate first responders.	Never leave an acid spill unattended

 **WARNING!** Risk of fire, explosion, or burns. Do not disassemble, heat above 158°F (70°C), or incinerate.

## b. Equipment Needed

The following is a list of equipment we recommend you have on hand as you inspect and care for your batteries.

- Goggles
- Rubber boots or rubber-soled shoes
- Insulated-handle wrench
- Voltmeter/multi-meter
- Battery charger
- Lined rubber gloves
- Distilled water
- Terminal protector (NO-OX-ID grease)
- Hydrometer
- Sodium Bicarbonate Solution: 1 cup of baking soda to 1 gallon of water (150 grams/liter)

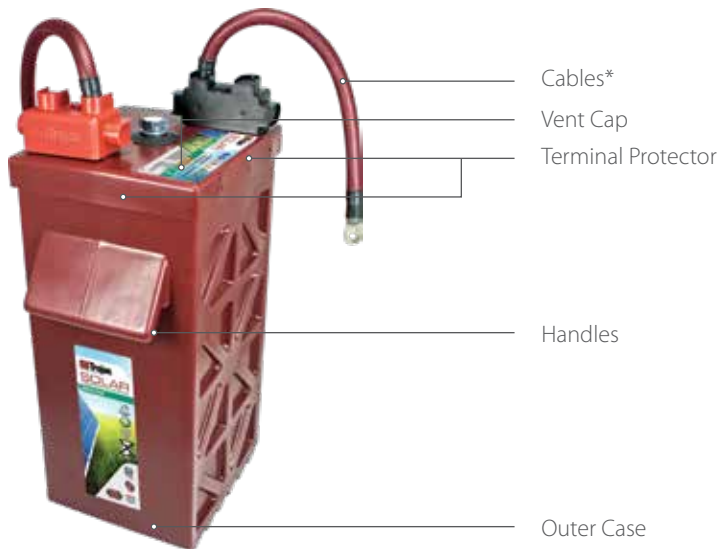

## c. Inspection

When you receive your batteries for the first time, follow these steps. If any problems are detected with the batteries, contact Trojan technical support or contact your battery distributor. If damage occurred in transit, contact your freight carrier.

*\*Trojan recommends using UL Listed cables, such as Trojan's premium-quality maroon cables.*

- ▶ **Conduct a visual inspection.** Check for visible damage including cracks, dents, deformation and other visible abnormalities. The tops of the batteries and terminal connections should be clean, free of dirt and corrosion, and dry. Any fluid on or around the battery could indicate that the case is not properly sealed or that the battery has been over-watered. Ensure that there is one cable per battery. Prior to the initial boost charge, make sure the electrolyte level covers the plates, but be sure not to overfill the battery as the level of electrolyte will rise during the charging process. Refer to the Watering Section on page 22 for more information about adding distilled water to your batteries.
- ▶ **Apply initial boost charge.** Trojan recommends applying a boost charge to your new batteries. A boost charge corrects voltage imbalances between individual cells and restores the battery to a fully charged state to maximize system performance. The term boost charge refers to fully charging your batteries before they are used.
- ▶ Two methods can be used to condition your new product. One is to use a charger that is automatic or pre-programmed. If this method is used, allow the charger to go through the full cycle. Some chargers allow the settings to be adjusted and to operate in a manual mode. In this situation use the following settings:
  - ▶ Boost charging at CONSTANT CURRENT, without voltage limit, may be carried out as specified: charge at 3% of  $C_{20}$  until the voltage stops increasing for three consecutive hourly readings. Under CONSTANT VOLTAGE conditions, the recommended boost charge voltage is 2.45 - 2.58 V/cell with the charger output current limited to 3-5% of  $C_{20}$ . Using voltages at the lower end of this range will result in an extended boost time.
  - ▶ The boost charge is not complete until the specific gravity readings of each cell remain constant over three successive hourly readings and all cells are gassing freely. If you have questions concerning initial boost charge, contact Trojan Battery Company's technical support.

#### **d. What to Expect from your Trojan Battery**

- ▶ It is expected that a new battery will need time to provide full, peak capacity. Trojan batteries take 50 – 100 cycles to work up to providing full amp-hour capacity.
- ▶ When operating batteries at temperatures below 86°F (30°C) they will deliver less than the rated capacity. For example at 5°F (-15°C) the battery will deliver 50% of the capacity it has at 86°F.

- ▶ When operating batteries at temperatures above 86°F (30°C) they will deliver more than the rated capacity, but the battery life will be reduced.

### Capacity vs. Temperature

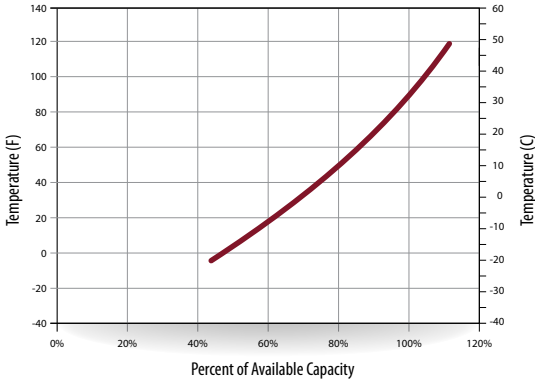

- ▶ The life of a battery varies by the temperature, depth of discharge, frequency of usage, level of maintenance and ambient conditions. The following graph shows the typical number of cycles for a Trojan Solar Industrial battery at  $C_{100}$  operating at 86°F (30°C).

### Typical Cycle Life of a Trojan Solar Industrial Battery in a Stationary Application

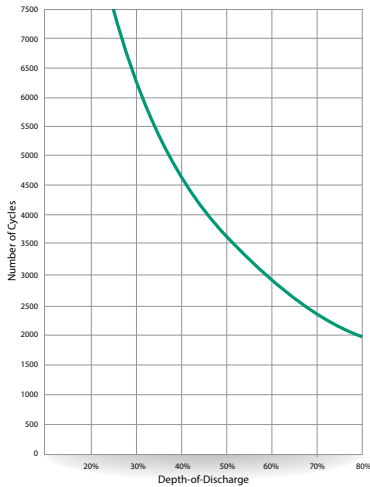



## 02 General Safety Instructions

### a. Important Electrical Safety Instructions

A battery can present a risk of electrical shock and high short circuit current. The following precautions should be observed when working with batteries. Failure to observe the precautions may result in injury or loss of life.

#### Warnings in this manual appear in any of three ways:



**Danger** – The danger symbol is an exclamation mark in a triangle and is used to indicate imminently hazardous situations, locations and conditions which, if not avoided, WILL result in death, serious injury and/or severe property damage.



**Warning** – The warning symbol is an exclamation mark in a triangle and is used to indicate potentially hazardous situations and conditions, which, if not avoided, COULD result in serious injury or death. Severe property damage COULD also occur.



**Caution** – The caution symbol is an exclamation mark enclosed in a triangle and is used to indicate potentially hazardous situations and conditions, which, if not avoided, may result in injury. Equipment damage may also occur.

*Other warning symbols may appear along with the Danger, Warning, and Caution symbols and are used to specify special hazards. These warnings describe particular areas where special care and/or procedures are required in order to prevent serious injury and possible death:*



**Electrical Warnings** – The electrical warning symbol is a lightning bolt mark enclosed in a triangle. The electrical warning symbol is used to indicate high voltage locations and conditions, which may cause serious injury or death if the proper precautions are not observed.



**Explosion Warnings** – The explosion warning symbol is an explosion mark enclosed in a triangle. The explosion warning symbol is used to indicate locations and conditions where molten, exploding parts may cause serious injury or death if the proper precautions are not observed.

1. Make sure all power sources to the batteries are off or disconnected from the batteries so they are not being charged while you are working on them. Disconnect all loads from the batteries before connecting or disconnecting terminals. (See Cable Installation Instructions on page 14)
2. Use appropriate lockout/tag-out procedures according to the appropriate code.

3. If working on an installed battery bank, disconnect the battery in sections to reach safe working voltage levels.
4. Remove all watches, rings, earrings or other metal objects.
5. Use tools with insulated handles.
6. Always wear protective clothing, goggles, lined rubber gloves and rubber boots.
7. Do not lay tools or metal parts on top of batteries.
8. Always keep the batteries in an upright position.
9. Determine if the battery is grounded (see Grounded and Ungrounded Batteries on page 10). If the system is grounded, remove the source of ground. Contact with any part of a grounded battery can result in electrical shock. The likelihood of such shock will be reduced if such grounds are removed during installation and maintenance. Protective grommets on positive cable connectors to the battery/cell terminals should be in position when not working directly on a specific terminal on any battery or cell within the system.
10. Verify circuit polarities before making connections by using a voltmeter or multi-meter.
11. Flooded lead acid (FLA) batteries can contain an explosive mixture of hydrogen gas. Do not smoke near batteries. Keep sparks, flames and metal objects away from batteries. This includes static electricity from the body and other items that may come in contact with the battery.
12. Charge and store batteries in a well-ventilated area.
13. Batteries can be heavy. Use proper lifting techniques when moving batteries.
14. Only dispose of lead acid batteries through channels in accordance with local, state and federal regulations. Batteries must NEVER be disposed of in household waste. For information about where to properly dispose of your batteries at the end of their life, contact Trojan technical support.
15. The electrolyte in a battery is a solution of acid and water. Avoid skin and clothing contact with the electrolyte. If acid contacts skin or eyes, flush with water immediately.
16. NEVER add acid to a battery. If for some reason a battery has leaked electrolyte, contact Trojan Battery technical support for instructions about what to do.



## **b. Electrical Shocks and Burns**



Battery banks can attain high voltage and/or currents. Do not touch non-insulated batteries, connectors or terminals. To prevent serious electrical burns and shock, use EXTREME CAUTION when working with batteries.

## C. Grounded and Ungrounded Batteries

A grounded battery or battery bank occurs when a battery terminal is connected to ground or when the battery racking is connected to ground with a current carrying conductor. Unintentional grounding can happen in a number of ways including direct wire coupling, coupling off their power source, electrolyte spilled from the battery, and tracking. If the battery bank is grounded, it is recommended, during installation and maintenance, to disconnect the battery bank from ground, as it can pose a serious risk of shock or an unintentional short-circuit.



If the battery or battery bank is grounded, a shock hazard exists between all other terminals and ground (i.e., dirt and acid on top of battery cell touching terminals, rack or any other ground). If an unintentional ground develops within the already grounded system, a short circuit may occur and cause explosion or fire.



For ungrounded batteries or battery banks, an unintentional ground could develop causing an increased shock hazard that exists between the terminals and ground. If a second unintentional ground develops within the already unintentionally grounded system, a short circuit may occur and cause explosion or fire.

If you are required to work on a grounded battery system, make absolutely sure you use the correct safety precautions, equipment and clothing.

## 03 Installation Considerations

When planning the system requirements for your Trojan Solar Industrial batteries, consider the following criteria:

- Space
- Environment
- Temperature
- Distance from operating equipment
- Floor Anchoring / Racking
- Ventilation
- Battery System Configuration / Layout
- Floor Loading / Material / Preparation
- Accessibility / Traffic / Maintenance
- Moving / Lifting batteries

### Space

Trojan recommends that the aisle space provided in front of the battery bank be a minimum of 36 inches (915 mm). The designer/installer must verify the requirements for aisle space in all applicable local codes or regulations. We recommend maintaining a minimum of 12 inches (305 mm) of free space above the tops of the battery terminal posts to permit access for maintenance or removal / replacement. Each battery should be accessible for the addition of distilled water and for taking voltage and hydrometer readings.

### Environment

Batteries should be stored in a clean, cool and dry place. The location should be selected to keep water, oil, and dirt away from all batteries. If any of these materials are allowed to accumulate on the batteries they can cause tracking and current leakage that can lead to self-discharge, and possible short-circuiting.

### Temperature

The recommended operating temperature range is -4°F to 122°F (-20°C to +50°C) with a humidity of <90%. Elevated temperatures can reduce operating life and lower temperatures can reduce battery performance. Temperatures below freezing must be avoided when batteries are in a discharged condition. The electrolyte may freeze which can ruin the cells. (Refer to the Capacity vs Temperature graph on page 7) It is important to minimize temperature variations between the cells. To avoid temperature variation between the cells, do not arrange the batteries where they are too tightly packed, restricting airflow. The minimum recommended spacing between the battery units is 1 inch (25 mm). Do not locate the batteries near HVAC ducts or exhausts, heat sources (i.e., equipment that generates heat) or in direct sunlight. Charging, especially at elevated temperatures, needs to be temperature compensated.

## Ventilation



Flooded/wet lead acid batteries release small amounts of hydrogen and oxygen gas during usage, particularly during the charging process. **It is critical to charge batteries in a well ventilated area.** Adequate ventilation must be provided to prevent hydrogen gas from exceeding a 2% concentration. The battery containment area must be designed and set up where the hydrogen accumulation can be limited to less than 2% of the total volume of the battery area to prevent possible explosion or flash burn. Flame propagation can begin at 2% but hydrogen pockets can accumulate at higher percentages so it is important to keep levels below 2%. Ventilation must be adequate to ensure that pockets of trapped hydrogen gas do not develop, particularly at the ceiling. For more assistance in calculating ventilation needs, please contact Trojan Battery Company's technical support.

## Codes

Building and fire codes may require special monitoring, unique electrical installation requirements and switch gear, fire protection and spill containment systems for battery installations. Please consult local building and fire codes.

## Floor

Batteries should be kept on a level surface. Sealed concrete, epoxy-coated concrete or membrane installed acid brick system capable of supporting the weight of the battery system and any associated equipment is preferable. Shim up to 1/4 inch per foot (6 mm per 305 mm) maximum to level battery rack or cabinet or shelving front to rear and side to side.

## Anchoring

Anchoring and isolation devices should meet all local, state and country codes, and all industry standards. Floor anchoring, seismic requirements and equipment/specifications and its design are the responsibility of the user.

## Racks

Trojan Battery Company does not supply racking systems with its batteries. Use of any rack design is the responsibility of the battery system user.

## 04 Battery Connections

Battery cables provide the link between the batteries, equipment and charging system. Faulty connections can lead to poor performance and terminal damage, meltdown or fire. To ensure proper connections, please use the following guidelines for terminal connections, cable sizing, torque values and terminal protection.

### a. Terminal Connections

- I. Each battery has a positive and negative terminal that is clearly marked on the top of the battery. Battery cables are connected to the battery terminals and run from one battery to the next to create a battery bank. Batteries can be connected in series and/or parallel (see pages 17-19). If the system design requires more than one cable per terminal, bolt the second cable to the same location on each terminal of the same battery.
- II. When using a washer to connect a battery cable to a battery terminal, it is very important to ensure the battery cable is contacting the lead surface of the terminal and that the washer is placed on top of the cable. Do not place the washer between the battery terminal and the battery cable, because it creates high resistance and can cause terminal meltdown. See page 14 for cable installation instructions.



### b. Cable Size

Battery cables come in different sizes and it is important to choose the correct battery cable size for your system. Battery cables should be sized to handle the expected load. All series cables and all parallel cables in a system should be the same length so that all strings have the same resistance.

- ▶ Trojan provides a highly flexible 4/0 cable and hardware (one per each Solar Industrial battery) that has been engineered and constructed with UL/CSA Listed or Recognized components and processes that should result in many years of extended battery life for series connections. It is important to determine the appropriate cable size for your application. Parallel cables and output cables are not included, but can be purchased from your preferred renewable energy supplier.
- ▶ When choosing the battery cable size, always assume that any string can end up being used to provide the full load current in the event of faulty strings.
- ▶ All cable sizing is the responsibility of the installer.
- ▶ For correct cable/wire sizing refer to the National Electrical Code, which is located at [www.nfpa.org](http://www.nfpa.org)



### C. Torque Values



Tighten all cable connections to the proper specification to make sure there is good contact with the terminals. Over-tightening the connection to the terminal can result in terminal breakage and loose connections which can result in meltdown or fire. Refer to Table 1 for the proper torque values based on the type of terminal on your battery.

**Table 1: Torque values**

Terminal Type	Dry Torque (in-lb)	Dry Torque (Nm)
IND	100 – 120	11 – 14

### d. Cable Installation Instructions



Properly connecting the battery cable to the battery terminal is important to ensure that a solid electrical connection is made, and to reduce the risk of injury, system malfunction or fire. To properly connect the cable to the terminal, remove the terminal protectors as noted in the Terminal Protection Installation section on page 15.

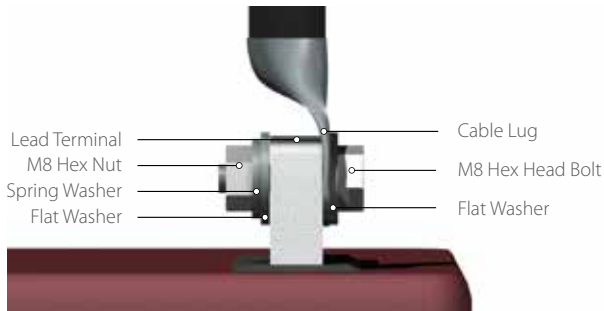

- ▶ Using a small piece of steel wool or small wire brush, clean the surface of the lead terminal of the battery on the side the cable lug will be bolted to.
- ▶ Using a paintbrush, apply a light coat of NO-OX-ID grease, that has been heated in hot water just to the point of thinning, to the contact surface of the terminal.
- ▶ Place the flat side of the cable lug as illustrated above directly on the lead terminal of the battery.
- ▶ Place one of the stainless steel flat washers supplied on the stainless steel M8 hex head bolt against the inside head of the bolt.

- Place the hex head bolt with the installed washer through the cable lug and through one of the holes in the lead battery terminal.
- Place the second stainless steel flat washer on the end of the bolt protruding through the terminal and against the flat side of the lead battery terminal.
- Place the stainless steel split spring washer on the end of the bolt that is protruding through the terminal, against the flat washer.
- Install the hex stainless steel M8 nut on the bolt and tighten the nut with your fingers. Do not torque the bolts until all the cables are installed to allow some adjustment of position.
- After all connections are assembled, torque all stainless steel connector bolts to 100-120 inch-lbs (11-14 Nm).
- Using a paintbrush, apply a light coat of the heated NO-OX-ID grease to the bolted connection, making certain to coat the cable lug, stainless steel bolt, washers and nut. Do not apply the NO-OX-ID grease to the cable insulation or the plastic parts of the battery.

Make certain the flat side of the cable lug is bolted directly to the lead terminal of the battery. Do not place a washer or any other material, other than the light film of NO-OX-ID grease, between the cable lug and the lead terminal as this can increase resistance which can generate heat and destroy the terminal, the cable and become a fire hazard. A loose connection between the battery cable and the battery terminal can have the same result. Make sure that all bolted battery connections are torqued to the recommended values. Use wrenches with a rubber handle to tighten all connections. Be cautious not to touch both terminals at the same time with a metal object as this can create a short circuit. Wear protective rubber gloves, rubber boots and eye protection at all times when working on batteries.



## E. Terminal Protection Installation

Trojan Solar Industrial batteries include terminal protectors for the purpose of keeping the terminals clean and dry in order to avoid corrosion and short-circuiting. Cable installation requires the removal of the terminal protectors which involves the following steps:



- ▶ The protector has two locating pins that fit through the holes of the terminal.
- ▶ The protector is made of two parts that are held together with a simple latch that snaps through a lock clip. To remove the protector, simply squeeze the latch pins toward the center to clear the latch while pulling gently on each part. Do not use excessive force, as the part or latch could break.
- ▶ Once the cable connection is in position, determine which knockout to remove on the protector so the cover will slip over the cable end and the two parts of the protector will latch back together. There are four locations to choose to cover most installations. To remove the knockout, simply twist or remove with pliers.
- ▶ Remove the locating pin in the large half of the protector where the cable goes through the terminal hole to allow the part to snap in place and back together. If the terminal has two cables connected to it, both pins should be removed and both knockouts should be used in the large half of the protector. The pin will snap off or can be cut off with snips. If dual cables are utilized, the protector will be held in place by the cables.
- ▶ Only service one protector and make one connection at a time to assure the battery is not shorted or inadvertently grounded.
- ▶ If the system is relocated, and the connector will not work with the new installation, replace with a new protector to assure the system is safe.

## 05 Connecting Batteries to Increase Capacity



### a. Series vs. Parallel Connections

Batteries can be connected in series or parallel, or a combination of both. A series connection involves using a battery cable to connect the positive terminal of one battery to the negative terminal on another. A series connection increases the voltage by adding the voltage of the connected batteries, but amp-hour capacity does not increase. A parallel connection involves using a battery cable to connect the positive terminal of one battery to the positive terminal of another battery, and a second battery cable to connect the negative terminal of one battery to the negative terminal of another battery. A parallel connection increases the amp-hour capacity by adding the amp-hour capacity of the connected batteries, but does not increase the voltage. To increase both the voltage and amp-hour capacity, batteries can be connected in series and parallel.

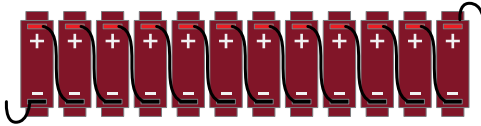
**Table 2:** Series Example

Individual Battery Unit: SIND 02 2450	
Voltage	Capacity
2V	2,450 Ah at C <sub>100</sub>
	
Battery Bank in Series: Twelve SIND 02 2450 Batteries in Series	
Voltage	Capacity
24V	2,450 Ah at C <sub>100</sub>
	

### Parallel Example

Individual Battery Unit: SIND 02 2450	
Voltage	Capacity
2V	2,450 Ah at C <sub>100</sub>
	
Battery Bank in Parallel: Two SIND 02 2450 Batteries in Parallel	
Voltage	Capacity
2V	4,900 Ah at C <sub>100</sub>
	

Note: While this example illustrates how to connect batteries in parallel, most renewable energy applications will require a 12V, 24V or 48V battery bank due to the inverter input voltage requirements.

### Series/Parallel Example

Individual Battery Unit: SIND 02 2450	
Voltage	Capacity
2V	2,450 Ah at C <sub>100</sub>
	

### Battery Bank in Series and Parallel: Twenty Four SIND 02 2450 Batteries in Series and Parallel

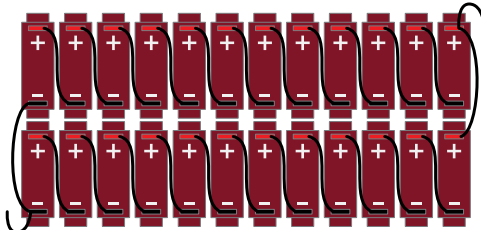
Battery Bank Voltage	Battery Bank Capacity
2V x 12 units = 24V	4,900Ah at C <sub>100</sub>
	

#### **b. Battery Orientation**

Flooded/wet batteries must be placed upright at all times. Liquid electrolyte in the battery may spill if the battery is placed on its side or at an angle.

Due to the dual container design of the Solar Industrial Line, Trojan recommends installing the batteries in a battery room, on a sealed concrete or brick floor. If and when the batteries are installed in a battery rack designed for the Solar Industrial line, the batteries should sit on the bottom of the rack and should not be suspended by the handles. Trojan doesn't provide battery racks. Please contact your Renewable Energy supplier for racks.

## **06 Battery Maintenance**

The following is the recommended minimum schedule for proper maintenance and record keeping. Readings should be taken when battery is at full state of charge and under no load. The Trojan Solar Industrial line warranty requires that records be kept on the Battery Maintenance Log Sheet (center of guide) and is available for download on our website at [www.trojanbattery.com](http://www.trojanbattery.com). Wear protective rubber gloves, rubber boots and eye protection at all times when working on batteries.



### **Inspect Monthly**

- Review general appearance and cleanliness of battery and battery area.
- Check electrolyte levels by removing vent caps and looking into vent wells.
- Look for evidence of electrolyte leaks on ground.
- Check for cracks in cells or leakage of electrolyte.
- Review terminals and connectors for corrosion.
- Record ambient temperature so there is a record of the temperature history.
- Review condition of ventilation equipment.
- Record cell voltage using a voltmeter.
- Record specific gravity using a hydrometer and electrolyte temperature with a hydrometer and a thermometer.
- Check charge controller or inverter/charger settings for manufacturer recommendations.

All of this information should be recorded on the Battery Maintenance Log Sheet and should be kept for the duration of the life of the battery.

### **Inspect Annually**

In addition to the monthly items, also do the following checks on an annual basis:

- Check all bolted connections to see if tightening is required. Tighten all bolted connections to the proper specifications listed on page 14.
- Check the integrity of the rack, stand, battery tray, or other accessories as needed.
- Check the area around the battery to ensure that nothing can fall on or short out the battery string.

This data will be required for any warranty claim made on the battery. For battery bank protection and to suit local conditions/requirements, more frequent readings may be necessary or required.

## **a. Preventative Maintenance**

It is important to inspect the batteries for cleanliness at regular intervals and keep cell terminals and connectors free of corrosion. Terminal corrosion may adversely affect the performance of the battery, and it could present a safety hazard.

## **b. Standard Cleaning**

1. Disconnect the battery from the charging source and the load.
2. Wipe off any accumulation of dust on the cell covers with a cloth dampened with clean water.
3. Check that all vent caps are secured properly on the battery.
4. If the cell covers or jars are damp with spilled electrolyte, wipe with a cloth dampened with a sodium bicarbonate solution (1 cup of baking soda to 1 gallon of water (150 gr/1lt)). Do not allow cleaning solution to get inside the battery.
5. Wipe down top and sides of battery with sodium bicarbonate solution and then wipe dry with a clean cloth. Do not allow cleaning solution to get into battery. If a spill occurs, take appropriate action to contain any spill. Neutralize any spills with the sodium bicarbonate solution.

## **c. Terminal and Connector Cleaning**

**Mild Corrosion** In cases where mild corrosion on the terminals or connectors is present, using the same sodium bicarbonate solution that was used to clean the top of the battery, take a soft bristled brush and gently brush down all terminals and wipe dry with a clean cloth. Reapply a light coating of NO-OX-LD to all connections.

**Heavy Corrosion** In cases where heavy corrosion on the terminals or connectors is present, unbolt and remove all connectors, apply the sodium bicarbonate solution mentioned above to cell posts and connectors to neutralize the corrosion. Clean contact surfaces by rubbing posts and terminals with non-metallic stiff bristle brush or non-metallic scouring pad. Do not remove the plating from the connectors. If copper is exposed on connectors, replace the cables. If the cables need to be replaced, follow the same process outlined for originally attaching the connectors (see page 14). Keep the area around batteries clean and dry.



## **07 Watering**

It is important to periodically add distilled water to your flooded batteries. The electrolyte level in a flooded lead acid battery will gradually lower over time as hydrogen and oxygen gases are released through the vent caps due to electrolysis, a normal battery process. The rate at which the water in the electrolyte is depleted depends on the battery cell temperature and humidity. The frequency of watering depends upon battery usage and operating temperatures. Check new batteries every few weeks to determine the watering frequency for your application. It is normal for batteries to need more frequent watering as they age. When adding distilled water to your batteries, please keep these points in mind:

- ▶ Remove the vent caps from each cell and place them upside down so that dirt does not get on the underside of the cap. Check the electrolyte level by looking into the vent wells.
- ▶ If the electrolyte level is barely covering the plates, add distilled water to a level 1/2" (13 mm) below the vent well. The plates should never be exposed.

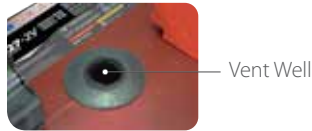

- ▶ If the electrolyte level is above the plates then it is not necessary to add more distilled water.
- ▶ Only add distilled water to the battery when the battery is at full state of charge. Only add water to discharged or partially charged batteries if the plates are exposed. In this case, add just enough water to cover the plates and then charge the batteries. Once the batteries are fully charged, continue with the watering procedure below.
- ▶ Only add distilled water to the battery. Tap water, river water, filtered water, etc. all contain minerals that can shorten the battery's life. In cases where no distilled water is available, use the cleanest water possible. It is more important to water the batteries with the cleanest water possible than to allow the plates to be exposed from lack of watering.
- ▶ After adding water, secure the vent caps back on the batteries.
- ▶ In cold climates with unheated battery rooms, water should only be added when the battery temperature is 45° F (7° C), or above.
- ▶ Do not store water in a metal container. Use a clean container made of glass, rubber or plastic. The container should not have been used to store anything but water in the past.
- ▶ If you have purchased a single-point watering system from Trojan Battery, please refer to the associated IOM (Installation, Operation and Maintenance) manual. Visit [www.trojanbattery.com](http://www.trojanbattery.com) to obtain more information about the single-point watering system.
- ▶ If distilled water is not available it is recommended to use water meeting the levels in Table 3.

**Table 3**

Recommended Maximum Allowable Impurities in Water for Battery Use		
Impurity	Parts Per Million	Effects of Impurity
Color	Clear and "White"	-
Suspended Matter	Trace	-
Total Solids	100	-
Organic and Volatile Matter	50	Corrosion of positive plate
Ammonia	8.0	Slight self-discharge of both plates
Antimony	5.0	Increased self-discharge, reduces life, lower on-charge voltage
Arsenic	0.5	Self-discharge, can form poisonous gas at negative plate
Calcium	40	Increase of positive plate shedding
Chloride	5.0	Loss of capacity in both plates, greater loss on the positive plate
Copper	5.0	Increased self-discharge, lower on-charge voltage
Iron	3.0	Increased self-discharge at both plates, lower on-charge voltage
Magnesium	40	Reduced life
Nickel	None Allowed	Intense lowering of on-charge voltage
Nitrates	10	Increased sulfation on the negative plate
Nitrites	5.0	Corrosion of both plates, loss of capacity, reduced life
Platinum	None Allowed	Increased self-discharge, lower on-charge voltage
Selenium	2.0	Positive plate shedding
Zinc	4.0	Slight self-discharge of negative plate



## **08 Charging and Storage**

### **a. Charging**

Proper charging is imperative to maximize battery performance. Both under or overcharging can significantly reduce the life of the battery. For proper charging, refer to the instructions that came with your charge controller and/or inverter/charger. Most charge controllers and inverter/chargers are automatic and pre-programmed, but they may allow the user to set the voltage and current values manually. Refer to Table 4 for Trojan's recommended voltage setting points for the Solar Industrial line for each charging stage described below.

Regardless of the charging stage, follow these rules to maximize battery charging performance:

- ▶ **Charge only in well-ventilated areas.**
- ▶ Check each battery cell's electrolyte level to make sure the plates are covered with electrolyte before charging.
- ▶ Check that all vent caps are secured properly on the battery before charging.
- ▶ Ensure the charge controller and/or inverter/charger is set to the appropriate charge algorithm for flooded/wet batteries.
- ▶ Lead acid batteries do not have a memory effect and therefore do not need to be fully discharged before recharging. Do not discharge your battery more than 80%. This safety factor will eliminate the chance of over-discharging and damaging your battery. Renewable energy applications are typically designed for a 20% - 50% depth of discharge.
- ▶ Flooded/wet batteries will gas (bubble) towards the end of a charge to ensure the proper mixing of the electrolyte.
- ▶ Never charge a frozen battery.
- ▶ Avoid charging at temperatures above 120°F (49°C), if possible, to maximize the battery life.

**Table 4**

Charge Controller and/or Inverter/Charger Set Points for Trojan Solar Industrial Batteries					
Voltage		2V	12V	24V	48V
Minimum / Maximum	Minimum Charge Voltage				
	Maximum Charge Voltage	2.7	16.2	32.4	64.8
	Maximum Charge Current	20% C <sub>20</sub> Capacity	20% C <sub>20</sub> Capacity	20% C <sub>20</sub> Capacity	20% C <sub>20</sub> Capacity
	Temperature Compensation	Subtract 0.005 volt per cell for every 1°C above 25°C or add 0.005 volt per cell for every 1°C below 25°C			
	Low Voltage Disconnect (LVD)	1.94	11.64	23.28	46.56
	LVD Re-Connect				
	Min / Max Notes	System set points above or below the minimum and maximum recommendations may void warranty.			
Boost	Boost Charge Voltage	2.58	15.48	30.96	61.92
	Boost Charge Current	3-5% C <sub>20</sub> Capacity	3-5% C <sub>20</sub> Capacity	3-5% C <sub>20</sub> Capacity	3-5% C <sub>20</sub> Capacity
	Boost Charge Time	Boost charge complete when specific gravity readings are constant over three successive hourly readings.			
	Boost Charge Notes	Boost charge may also be completed with constant current without voltage limit method at 3% C <sub>20</sub> Capacity.			
Bulk	Bulk Charge Voltage	2.47	14.82	29.64	59.28
	Bulk Charge Current	10-13% C <sub>20</sub> Capacity	10-13% C <sub>20</sub> Capacity	10-13% C <sub>20</sub> Capacity	10-13% C <sub>20</sub> Capacity
	Bulk Charge Time	Most charge controllers and inverter/chargers will automatically control bulk charging based on voltage.			
	Bulk Charge Notes				
Absorption	Absorption Charge Voltage	2.35	14.1	28.2	56.4
	Absorption Charge Current	Decreases as battery voltage is held constant			
	Absorption Charge Time	Varies depending on depth of discharge and charge current			
	Absorption Charge Notes	Most charge controllers and inverter/chargers will automatically control absorption charging based on voltage.			
Float	Float Charge Voltage	2.25	13.5	27	54
	Float Charge Current	Varies as voltage is held constant			
	Float Charge Time	Not required			
	Float Charge Notes	Maintains full state of charge by compensating for self-discharge			
Equalize	Equalize Charge Voltage	2.7	16.2	32.4	64.8
	Equalize Charge Current	Varies as voltage is held constant. Should be limited to 5-10% C <sub>20</sub> .			
	Equalize Charge Time	2-4 hours (if automatic) every 30 days			
	Equalize Charge Notes	Equalization complete when specific gravity readings are constant over three successive readings taken every 30 minutes.			

The chart below illustrates a typical recharge profile:

## Recommended Deep-Cycle Flooded/Wet Charging Profile

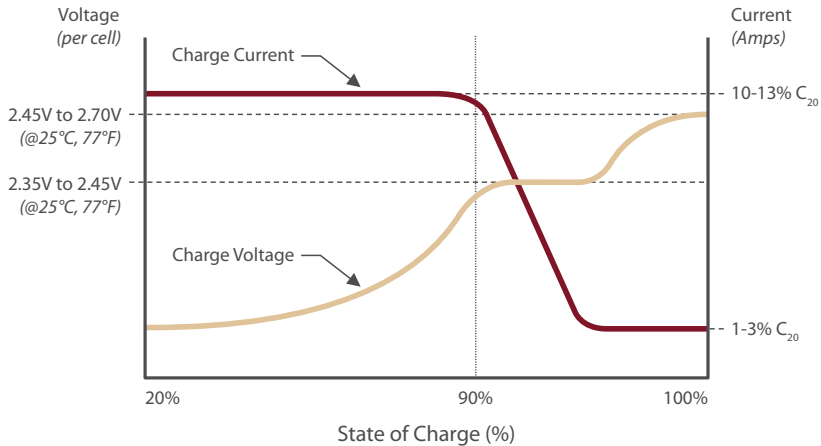

*Note: Charging time will vary depending on battery size, charger output, and depth of discharge.*

### Charging

1. Initial Boost Charge — An initial boost charge is a charge given to batteries to correct possible voltage imbalances between individual cells or correct a battery that has self-discharged after shipment or while in storage. An initial boost charge restores the battery to its full state of charge, and involves a short period of overcharging which releases gas and mixes the electrolyte to prevent stratification. In addition, an initial boost charge assists in keeping all batteries in a battery bank at the same capacity.
2. Bulk Charge — The first part of the battery charging process is typically a Constant Current (CC) charge mode, when the maximum amount of current flows into the battery until a desired voltage is reached, typically called the “gassing voltage” or “absorption setting voltage.” A bulk charge normally charges a flooded battery to 85-90% SOC level. Bulk charge voltage set points are outlined in Table 3. The recommended bulk charge current is 10-13% of C<sub>20</sub>. Lower bulk charge currents will result in longer recharge time. The maximum bulk charge current is 20% of C<sub>20</sub> provided battery temperature does not increase by more than 20°F above ambient conditions. If battery temperature increases by more than 20°F above ambient conditions, charge current should be reduced as this indicates the current is not being accepted by the batteries.

3. Absorption Charge — While a bulk charge only recharges a flooded lead acid battery bank to 85-90% SOC level, an absorption charge continues the charging cycle to bring the flooded lead acid battery bank to approximately 97-99% SOC. The absorption charge stage is achieved through a Constant Voltage (CV) mode. Most solar charge controllers and inverterchargers allow you to adjust the duration of the absorption charge mode for the required time to bring the battery bank to the next step charge mode (i.e. the floating charge mode, or the periodic equalization charge mode). The initial absorption time (T) can be estimated using the following formula:  $T = 0.4 \times C / I$ , where C is the 20 hour capacity rating of the battery bank and I is the charge current. However, it may be necessary to adjust the absorption time based on the specific gravity readings obtained during float charge. Absorption charge voltage set points are outlined in Table 4. A nominal full charge (absorption charge + floating charge) is recommended every three days.
4. Float Charge — Float charge is the final stage in the three stages of charging, which includes bulk and absorption charging, and occurs when a battery is approximately at 97-99% SOC and no load is drawing on the batteries. The charge current and voltage are reduced to maintain a full battery, providing just enough charging to compensate for self-discharge. It is a controlled constant voltage (CV) at a lower voltage than the absorption battery charging stage, and allows the batteries to maintain a full SOC by supplying constant voltage to the batteries. The solar charge controller or invertercharger determines when a float charge is needed, and is typically based on a timer and/or other parameters. A float charge is conducted once the absorption charge is complete and compensates for the self-discharge of a lead acid battery at a set voltage.
5. Equalization Charge — An equalization charge prevents battery stratification and reduces sulfation, the leading causes of battery failure. The equalization charge stage is achieved through Constant Voltage (CV) mode. It is a controlled overcharge at a higher voltage than is normally used in the float battery charging stage, and is required to bring each battery plate to a fully charged condition. Trojan recommends equalizing when fully charged batteries have a low specific gravity reading below 1.230, or wide ranging specific gravity that is 0.050 between the battery's cells. If using a charge controller or invertercharger with automatic equalization, Trojan recommends equalizing the Solar Industrial batteries every 30 days. To equalize your batteries, set your solar charge controller/invertercharger to "equalization", or manually charge the batteries until voltage elevates to the equalization voltage shown in Table 4. Current should be limited to 5-10% of  $C_{20}$  during equalization. A constant specific gravity reading taken every 30 minutes is a good indication of cell

equalization.

Equalization can be performed by following this procedure:

- ▶ Check the battery's electrolyte level in each cell to make sure the plates are covered with electrolyte before charging.
- ▶ Check that all vent caps are secured properly on the battery before charging.
- ▶ Set the charge controller or inverter/charger to equalize mode. Refer to the charge controller or inverter/charger manual for information about how to program the device.
- ▶ *Note: For a stand-alone photovoltaic (PV) system, an equalization charge can only be done when there is enough sun to fully charge the batteries, which may not occur daily.*
- ▶ The batteries will gas (bubble) during the equalization process.
- ▶ Measure the specific gravity of each cell of each battery every 30 minutes. Discontinue the equalization charge when the specific gravity no longer rises. The length of time to equalize a battery bank depends on the size of the system, the power source and the system components.
- ▶ Trojan recommends any automated system should be set to equalize Solar Industrial batteries at least every 30 days. A full charge is recommended at least every three nominal charge throughputs. A charge throughput is when a battery is taken from the end of charge, is discharged, and then taken to the end of charge again. A nominal charge throughput is reached when the sum of the discharge currents corresponds to the nominal capacity of the battery.

## **b. Storage**

Always do an initial boost charge to your batteries before placing them in storage.

- ▶ Store in a cool, dry location protected from the elements.
- ▶ Disconnect from equipment to eliminate potential parasitic loads that may discharge the battery.
- ▶ Batteries gradually self-discharge during storage. Monitor the specific gravity or voltage every four to six weeks. Stored batteries should be given another initial boost charge when they are at 70% state of charge (SOC) or less. Refer to Apply Initial Boost Charge on page 6 to learn about initial boost charging and refer to Table 5 for nominal specific gravity and voltage measurements at 80°F (27°C). Specific gravity changes as the battery ages causing the range to be +/- 7 points depending on the age of the battery.
- ▶ When batteries are taken out of storage, recharge them with another initial boost charge before use.

**Table 5**

Trojan Solar Industrial Battery State of Charge as a Measure of Specific Gravity and Open-Circuit Voltage					
Percentage Charge	Specific Gravity	Cell	12 Volt	24 Volt	48 Volt
100	1.260	2.11	12.66	25.32	50.64
90	1.246	2.09	12.54	25.08	50.16
80	1.227	2.07	12.42	24.84	49.68
70	1.207	2.05	12.30	24.60	49.20
60	1.187	2.03	12.18	24.36	48.72
50	1.165	2.01	12.06	24.12	48.24
40	1.142	1.99	11.94	23.88	47.76
30	1.119	1.96	11.76	23.52	47.04
20	1.096	1.94	11.64	23.28	46.56
10	1.072	1.92	11.52	23.04	46.08

Note – When taking specific gravity readings, corrections must be made for variations in temperature of the electrolyte. Correct the specific gravity readings for temperature by adding 0.004 for every 10°F (5°C) above 80°F (27°C) and subtract 0.004 for every 10°F (5°C) below 80°F (27°C).

Storage in hot environments (greater than 90°F or 32°C): When storing your batteries, avoid direct exposure to heat sources, if possible. Batteries self-discharge faster in high temperatures. If batteries are stored during hot, summer months, monitor the specific gravity or voltage more frequently (approximately every two to four weeks).

Storage in cold environments (less than 32°F or 0°C): When storing your batteries, avoid locations where freezing temperatures are expected, if possible. Batteries can freeze in cold temperatures if they are not fully charged. If batteries are stored during cold, winter months, it is critical that they are kept fully charged.

## 09 Troubleshooting

The following information includes three different battery-testing procedures that are only guidelines for identifying a battery that may need to be replaced. Unique situations may be observed that are not identified within these procedures. Please contact Trojan Battery Company's technical support at 800-423-6569 Ext. 3045 or +1-562-236-3045 and [technical@trojanbattery.com](mailto:technical@trojanbattery.com) for help interpreting the test data. Please note that specific gravity and voltage readings recorded regularly on the Battery Maintenance Log Sheet must be provided for warranty claims.

Before testing your battery, please follow these steps:

- ▶ Check that all vent caps are secured properly on the battery.
- ▶ Clean the top of the battery, terminals and connections with a cloth or brush and a solution of sodium bicarbonate solution. Do not allow cleaning solution to get inside the battery. Rinse with water and dry with a clean cloth.
- ▶ Check battery cables and connections, replace any damaged cables and tighten any loose connections. Refer to Torque Values Section 04.
- ▶ Check the electrolyte level and add distilled water if necessary. For information on how to water your batteries, refer to Watering, Section 07.
- ▶ Fully charge batteries before conducting any tests.



### a. Specific Gravity Testing

Equipment needed:

- ▶ A hydrometer
- ▶ Rubber gloves, goggles, apron, rubber boots
- ▶ Water
- ▶ Battery Maintenance log book
- ▶ Sodium Bicarbonate Solution

A specific gravity reading is the most accurate way to determine a battery's state of charge. This measurement is based on the density of the electrolyte compared to the density of water and is typically determined by the use of a hydrometer. The specific gravity of water is 1.000 and the specific gravity of the sulfuric acid electrolyte in a typically fully charged Solar Industrial battery is 1.260. Specific gravity measurements are used to determine if the battery is fully charged or if the battery has a weak or a bad cell. A high specific gravity means a higher density of acid to water, which normally indicates a higher state of charge. Specific gravity should be measured when the battery is not under a load and should not be measured soon after water is added to the battery.

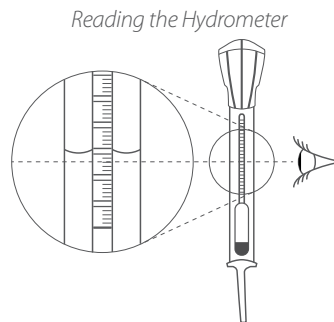

While there are many hydrometers available on the market, not all are designed for use with Trojan deep-cycle Solar Industrial batteries.

Wear eye protection, rubber gloves and have sodium bicarbonate solution and water on hand in case of acid spills.

To find the specific gravity of your battery's cells, follow these steps:

- ▶ Use a hydrometer that measures within five grading points or less
- ▶ Fill and drain the hydrometer with electrolyte two-three times before drawing a sample from the battery.
- ▶ Take a sample of the electrolyte. The sample must be large enough to completely support the float. Hold the hydrometer in a vertical position so the float is not touching the sides, top, or bottom of the tube. Look straight across the electrolyte level to read the float as shown above.
- ▶ Record the specific gravity readings for all battery cells on your Trojan Battery Maintenance Log Sheet.
- ▶ Correct the specific gravity readings for temperature by adding 0.004 for every 10°F (5°C) above 80°F (27°C) and subtract 0.004 for every 10°F (5°C) below 80°F (27°C).
- ▶ If every cell in the battery bank is below 1.230, the batteries may be undercharged; recharge batteries.
- ▶ If any battery has a specific gravity variation of more than 0.050 between cells, equalize the battery bank. For information on Equalization, refer to page 27.
- ▶ If there is still a variation of more than 0.050 between cells after equalizing, it may indicate a failed battery. If this occurs, contact Trojan technical support.
- ▶ After testing, rinse the hydrometer out with fresh water at least five times to flush the acid out.
- ▶ A refractometer can also be used to measure specific gravity.





## **b. On-Charge Voltage Testing**

Equipment needed:

- Voltmeter or Multi-Meter
- Battery Maintenance Log Sheet
- Rubber Gloves, Goggles, Apron, Rubber Boots



On-charge voltage testing is a secondary test to verify that there is a problem if the specific gravity test indicates something was wrong. An on-charge voltage test is done when there is a load connected to the battery. This test indicates if the charge controller is working properly.

- Disconnect and reconnect the DC power source to the charge controller to restart the charge controller manually if required.
- While the batteries are on-charge (not float charging) record the current in the last ½ hour of charge (if possible) and measure the battery bank voltage.
- While the batteries are on-charge measure the individual battery voltages with a voltmeter.
- If any battery voltage is below: 2.33V for 2V, 4.66V for a 4V, or 7.0V for 6V battery, and a voltage variation is greater than 0.17V for a 2V battery, 0.33V for a 4V battery, 0.5V for 6V battery, from one battery to another in a set, it may indicate a failed battery.
- Record data on the Battery Maintenance Log Sheet for warranty. Determine if there is a bad battery in the set – replace if necessary.
- If any battery voltage variation is greater than 0.33V for 2V, 0.47V for 4V, or 0.7V for 6V battery from any other battery in the battery bank, equalize the battery bank. Refer to Equalizing on page 27. After equalizing the battery bank, re-measure the individual battery voltages. If any battery voltage variation is still greater than 0.33V, 0.47V or 0.7V respectively, from any other battery in the battery bank, you may have a failed battery.



## **c. Open Circuit Voltage Testing**

Equipment needed:

- Voltmeter or Multi-Meter
- Battery Maintenance Log Sheet
- Rubber Gloves, Goggles, Apron, Rubber Boots



Open circuit voltage testing is used to determine the battery's state of charge, however it is not as accurate as a specific gravity test, which measures each battery cell. The test is done when the load is disconnected from the battery.

- ▶ For accurate voltage readings, batteries must remain idle (disconnected from the power source and the load) at least 6 hours, but preferably up to 24 hours.
- ▶ Measure the individual battery voltages with a voltmeter.
- ▶ If the battery voltage difference is 0.33V for 2V, 0.47V for 4V, or 0.7V for 6V greater than the other batteries in battery bank, equalize the battery bank. Refer to page 27 for more information on Equalization. After equalizing the battery bank, re-measure the individual battery voltages. If any individual battery voltage is 0.33V for 2V, 0.47V for 4V, or 0.7V for 6V lower than any other battery in the battery bank, you may have a failed battery.
- ▶ If the battery voltage difference is not greater than 0.3V than any other battery in the battery bank, no problem is indicated.
- ▶ Record data on the Battery Maintenance Log Sheet for future reference.

While other methods of testing batteries exist, including internal resistance (i.e. CCA testers) and carbon-pile discharge testers, these are not suitable testing methods for deep-cycle batteries.

## **10 Battery Recycling**

Lead acid batteries are more than 97% recyclable. In fact, lead acid batteries top the list of the most highly recycled consumer products and Trojan Battery supports proper recycling of your battery to keep the environment clean. Lead acid batteries should never be discarded as household waste.

Please contact Trojan Battery to find out the nearest recycling facility in your area to properly recycle your batteries.

Next page is the process in which your Trojan battery will be recycled.

# Recycling For A Better Environment

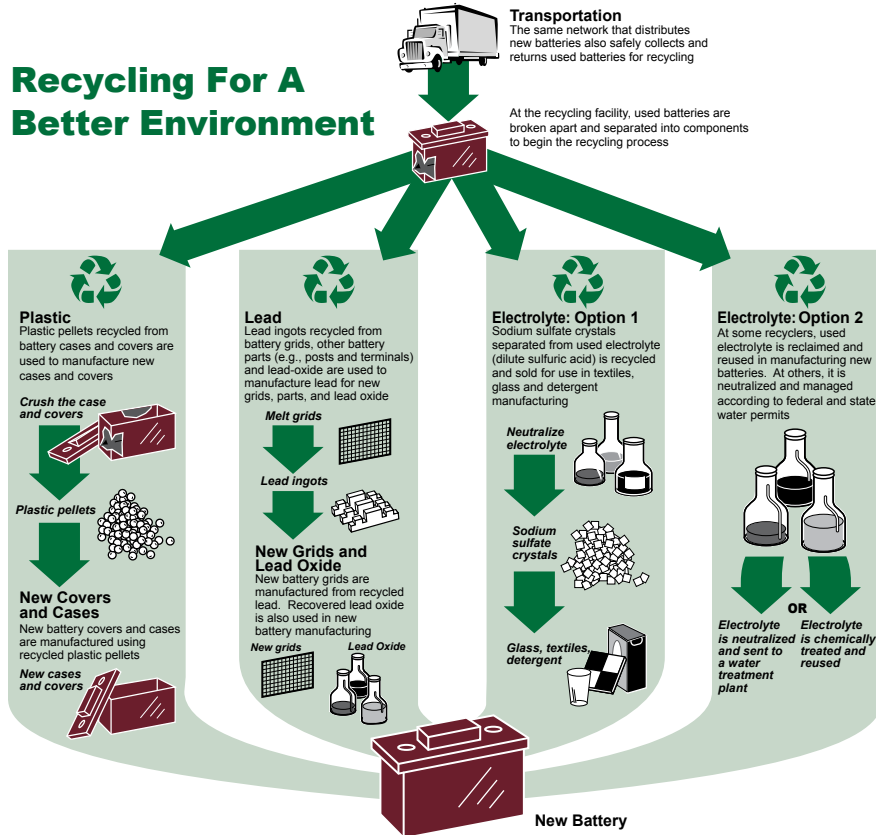

## 11 Warranty Information

Trojan's Solar Industrial line of flooded deep-cycle batteries is covered by an 8-year warranty period; some restrictions may apply. Please refer to the full RE warranty document at [www.trojanbattery.com/tech-support/rew](http://www.trojanbattery.com/tech-support/rew) for more information.

## 12 Battery Maintenance Log Sheet

A sample of Trojan's Battery Maintenance Log Sheet is located in the center of the user's guide or visit [www.trojanbattery.com/pdf/BatteryMaintenanceLog.pdf](http://www.trojanbattery.com/pdf/BatteryMaintenanceLog.pdf) to download.

## 13 Glossary of Terms

### Absorption Charge

While a bulk charge only recharges a flooded lead acid battery bank to 85-90% SOC level, the absorption charge continues the charging cycle to bring the flooded lead acid battery bank to approximately 97-99% SOC. The absorption charge stage is achieved through a Constant Voltage (CV) mode. Most solar charge controllers and inverter-chargers allow you to adjust the duration of the absorption charge mode for the required time to bring the battery bank to the next step charge mode (i.e. the floating charge mode, or the periodic equalization charge mode). The initial absorb time (T) can be estimated using the following formula:  $T = 0.4 \times C / I$ , where C is the 20 hour capacity rating of the battery bank and I is the charge current. However, it may be necessary to adjust the absorb time based on the specific gravity readings obtained during Float charge. Absorption charge voltage set points are outlined in Table 4 on page 25. A nominal full charge (absorption charge + floating charge) is recommended every three charge throughputs.

### Alternating Current

Electricity comes in two forms - direct current and alternating current. Alternating current means electrons run back and forth rapidly in opposing directions, causing the polarity of the current to alternate. In the United States, for example, electrons run back and forth at a rate of 60 times per second, i.e. 60 hertz. In Europe and other countries, the rate is 50 times per second, i.e. 50 hertz. While all lead acid batteries produce direct current, it can be converted to alternating current by using an inverter.

### Ampere (A)

A unit of electrical current flow, referred to as amps (A), measured by how many electrons flow past a given point each second.

### Amp-Hour (Ah)

A unit of electrical current over time. One amp of current flowing for one hour is 1 Ah. Amp-hour is the standard measurement for battery capacity. A battery's amp-hours multiplied by its voltage equals watt-hours.

### **Amp-Hour Capacity**

The number of amp-hours a battery can deliver for a specific period of time. Ah capacity is rated by a C-rate which indicates how many hours the battery can discharge the stated amp-hours. For example, a battery rated at 1,000 amp-hours at  $C_{20}$  at 1.75 V/cell will discharge 50 amps for 20 hours to a cutoff voltage of 1.75V per cell.

### **Battery Bank**

A group of batteries electrically connected together configured as one string or up to three strings in parallel. Each string consists of the necessary number of battery units in series to reach the required battery bank voltage.

### **Battery Capacity**

The total amount of electrical energy available from a battery usually expressed in amp-hours at a particular C-rate, unit voltage, cutoff voltage per cell (V/cell) and at a reference temperature.

### **Bulk Charge**

The first part of the battery charging process is typically a Constant Current (CC) charge mode, when the maximum amount of current flows into the battery until a desired voltage is reached, typically called the “gassing voltage” or “absorption setting voltage”. A bulk charge normally charges a flooded battery to 85-90% SOC level. Bulk charge voltage set points are outlined on page 25. The recommended Bulk charge current is 10-13% of  $C_{20}$ . Lower bulk charge currents will result in longer recharge time. The maximum Bulk charge current is 20% of  $C_{20}$  provided battery temperature does not increase by more than 20°F above ambient conditions. If battery temperature increases by more than 20°F above ambient conditions, charge current should be reduced as this indicates the current is not being accepted by the batteries.

### **Charge Rate (C-rate)**

Battery capacity is rated in amp-hours at a specific charge rate. The charge or discharge rate indicates how many hours the battery can discharge the stated amp-hours for a rated period of time. For example, a battery rated at 1,000 amp-hours at  $C_{20}$  at 1.75 V/cell will discharge 50 amps for 20 hours to a cutoff voltage of 1.75V per cell.

## Cell

Lead acid batteries are made up of individual cells which are 2V each. The Solar Industrial battery units configure in individual 2V cells assembled in 6V, 4V in dual-container configurations, or only one 2V cell in dual-containers for the 2V larger capacity models. Battery banks combine several Solar Industrial battery units together to form a battery bank with higher amperage and voltage than one individual Solar Industrial battery unit can provide.

## Charge Voltage

The voltage that is applied to each 2V cell during each Constant Voltage charging stage (absorption, float or equalization charge mode) . The voltage settings for the Solar Industrial flooded lead acid batteries are provided at Table 4, page 25.

## Current (I)

The rate of the flow of electrons in a circuit, measured in amperes.

## Cycle / Cycle Life

A “cycle” is a term used to describe the concept of discharging a battery to a particular state of charge, and then fully recharging the battery. Lead acid batteries are rated in “cycle life” which gives the user an indication of the useful life of the battery over a period of time. For example, a battery rated at 1,500 cycles at 80% depth of discharge will outlast a battery rated at 1,000 cycles at 80% depth of discharge, since it is capable of 500 more cycles at that discharge rate.

## Depth of Discharge (DOD)

Depth of discharge (DOD) describes how much of the total amp-hour capacity is used during a discharge cycle. For example, if a battery has a rated amp-hour capacity of 1,000 amps-hours at  $C_{20}$ , and 500 amp-hours are discharged from the battery, the battery has reached a 50% DOD. Deep-cycle batteries are designed to discharge up to 80% of their rated capacity without damage to the battery. The total number of cycles a battery can achieve in its life decreases as the level of DOD increases. For example, a battery that is regularly discharged to 80% DOD will achieve fewer cycles than a battery that is regularly discharged to 20% DOD.

## **Direct Current (DC)**

Electricity comes in two forms - direct current and alternating current. Direct current means electrons run continuously in one direction. All lead acid batteries produce direct current. Direct current can be converted to alternating current by using an inverter.

## **Electrolyte**

An electrically conductive solution in which current flows due to the movement of ions. In a flooded lead acid battery, the electrolyte is a liquid solution made up of sulfuric acid and water. When a flooded lead acid battery is used, hydrogen and oxygen escape through the vent caps, requiring distilled water to be added to each battery cell periodically to ensure the electrolyte always covers the lead plates.

## **Equalization / Equalizing Charge**

An equalizing charge prevents battery stratification and reduces sulfation, the leading causes of battery failure. The equalization charge stage is achieved through Constant Voltage (CV) mode. It is a controlled overcharge at a higher voltage than is normally used in the float battery charging stage, and is required to bring each battery plate to a fully charged condition. Trojan recommends equalizing the Solar Industrial batteries every 30 nominal charge throughputs. To equalize your batteries, set your solar charge controller/inverter-charger to “equalization”, or manually charge the batteries until voltage elevates to the equalization voltage shown on page 25. Current should be limited to 5-10% of  $C_{20}$  during Equalization. A constant specific gravity reading taken every 30 minutes is a good indication of cell equalization.

## **Float Charge**

A float charge is the final stage in the three stages of charging, which includes bulk and absorption charging, and occurs when a battery is approximately at 97 – 99% SOC and no load is drawing on the batteries. The charge current and voltage are reduced to maintain a full battery, providing just enough charging to compensate for self-discharge. It is a controlled constant voltage (CV) at a lower voltage than the absorption battery charging stage, and allows the batteries to maintain a full SOC by supplying constant voltage to the batteries. The solar charge controller/inverter charger determines when a float charge is needed, and is typically based on a timer and/or other parameters. A float charge is conducted once the absorption charge is complete and compensates for the self-discharge of a lead acid battery at a set voltage.

## **Gassing**

Hydrogen and oxygen are released when water molecules split as lead acid batteries are charged and discharged.

## **Hydrometer**

A hydrometer is a tool used to measure the specific gravity (SG) of the electrolyte within a flooded lead acid battery. The SG of the electrolyte indicates the battery's state of charge.

## **Initial Boost Charge**

An initial boost charge is a charge given to batteries to correct possible voltage imbalances between individual cells or correct a battery that has self-discharged after shipment or while in storage. An initial boost charge restores the battery to its full state of charge, and involves a short period of overcharging which releases gas and mixes the electrolyte to prevent stratification. In addition, an initial boost charge assists in keeping all batteries in a battery bank at the same capacity.

## **Mossing**

When shed material gets into the electrolyte and is lifted by gassing, it can be deposited on the top or sides of the element where it can build up, growing like moss, to form shorts when it reaches plates or straps of the opposite polarity. The natural plating action of the element during the discharge and charge helps to accumulate the particles to form the moss looking material that eventually shorts the cell. Trojan Solar Industrial batteries have plastic shields with "fingers" that fit under the straps between the plate lugs on both the positive and negative plates that insulate the tops of the plates preventing shorts due to moss buildup.

## **Nominal Voltage**

The cell voltage that is accepted as an industry standard. For lead acid batteries this is 2V. The battery bank nominal voltage is the total voltage reached by adding the number of individual 2V cells that are connected in series within one string and multiplying it by 2V. For example, a battery bank configured as one string or up to 3 strings in parallel, with each string consisting of 12x [2V cells]: the battery bank voltage is  $12 \times 2V = 24V$ .

## **Open Circuit Voltage (OCV)**

Open circuit voltage is the difference in electrical potential between two terminals of a device when disconnected from any load or circuit. Open circuit voltage indicates a good, yet imperfect, indication of a battery's state of charge. The higher the OCV, the higher the battery's state of charge. Open circuit



voltage can be measured using a voltmeter, but the preferred method to determine a battery's state of charge of a flooded lead acid battery is to check the specific gravity (SG) of the electrolyte using a hydrometer.

### **On-Charge Voltage**

On-charge voltage testing is a secondary test to verify problems if the specific gravity test indicates something is wrong. An on-charge voltage test is done when there is a charger connected to the battery. This test indicates if the charger controller is working properly.

### **Parallel Connection**

Connecting batteries in parallel (positive to positive and negative to negative) will increase the battery's amp-hour capacity, but the voltage will stay the same. For example, two batteries rated at 2V and 2,450 Ah that are connected in parallel will result in 2V at 4,900 Ah.

### **Partial State Of Charge (PSOC)**

When a lead acid battery is not fully charged or discharged, it is in a partial state of charge. This is common with renewable energy applications since the intermittent nature of the sun and wind do not always fully charge a battery bank each day. It is highly recommended to avoid letting batteries remain in a partial state of charge which could result in hard sulfation, one of the major causes of lead acid battery failures.

### **Self Discharge**

When batteries are not in use, they will lose their charge on their own. This process is called self-discharge. The rate of self-discharge depends on the ambient temperature, cell chemistry, and the length of time the batteries are not in use. Batteries self-discharge faster in warm temperatures.

### **Series Connection**

Connecting batteries in series (positive to negative) will increase the battery voltage, but the amp-hour capacity will stay the same. For example, two batteries rated at 2V and 2,450 Ah at  $C_{100}$  that are connected in series will result in 4V at 2,450 Ah.

### **Shed or Shed Material**

Loosened or worn out particles of active material fallen to the bottom of cells; frequently called "mud."

### **Short Circuit Current**

An electrical circuit that allows current to travel along an unintended path, often where essentially no, or very low resistance is encountered.

### **Smart Carbon™**

Trojan's Solar Industrial and Solar Premium Line of batteries now feature Smart Carbon™ for enhanced life and improved performance for Renewable Energy operating in Partial State of Charge (PSOC). Smart Carbon increases the electrochemically active surface area which provides improved charge acceptance and faster recharge in applications where the batteries are under-charged on a regular basis.

### **Solar Charge Controller / Inverter-Charger**

A device used in a renewable energy battery-based power supply system, connected between the energy source and the battery bank, that charges the battery bank using the energy source(s) and protects the battery bank from overcharge and over-discharge. Modern solar charge controllers / Inverter-chargers typically use pulse width modulation (PWM) or/and multiple power point tracking (MPPT) constant voltage charge algorithms. MPPT capabilities maximizes the power output from the solar energy source to the battery bank. A system designed without a solar charge controller / inverter-charger that would not charge the battery bank adequately, nor have the adequate charge protection, may result in shortened battery life and decreased power availability to the load.

### **Specific Gravity (SG)**

Specific gravity is a measure of the acid concentration in the electrolyte within a battery. This measurement is based on the density of the acid compared to the density of water, and is typically determined by using a hydrometer. By definition, the specific gravity of water is 1.000 and the specific gravity of the sulfuric acid electrolyte in a typical fully charged Solar Industrial battery is 1.260. Specific gravity measurements are used to determine if the battery is fully charged or if the battery has a weak or bad cell.

### **State of Charge (SOC)**

A measurement of the battery's charge relative to its capacity. State of charge can be determined by using a hydrometer to measure the flooded lead acid battery's specific gravity per cell, or by using a voltmeter to measure the battery's cell voltage.

### **Stratification**

The unequal concentration of sulfuric acid within the electrolyte due to density gradients from the bottom to the

top of the cell. This condition is encountered most often in batteries recharged from deep discharge at constant voltage without a great deal of gassing. Continued deep cycling of a stratified battery will result in softening of the bottoms of the positive plates. Equalization charging is a way to avoid acid stratification of the electrolyte.

### **Sulfation**

Sulfation is the generation or conversion of the discharged lead sulfate in the plates to a state that resists normal recharge. Sulfation develops when a battery is stored or cycled in a partial state of charge (PSOC), particularly at warm temperatures.

### **Terminal**

Every Trojan lead acid battery has two terminals - a positive terminal and a negative terminal. Battery terminals come in different shapes and sizes depending on the intended application. The terminals are connected to the plates inside the battery, allowing the terminals to carry current from the battery to the cables. Battery cables are connected to the lead terminals of the battery, allowing multiple batteries to be connected together to a charging source, and to a load.

### **Tracking**

Tracking is dust or mist that accumulates on the battery, which connect it to ground creating an unintentionally grounded battery. Tracking should be avoided as it presents a potential safety hazard.

### **Volt (V)**

A unit of measurement of electrical potential or “pressure.” Lead acid batteries come in 2V to 12V types and are made up of individual 2V cells. Most renewable energy battery bank designs are 12V, 24V or 48V. The Solar Industrial batteries configured as individual 2V cells that are assembled in series in 6V, 4V models housed in dual-container configurations, or, as a single 2V cell housed in dual-containers for the 2V larger capacity batteries.

### **Voltmeter**

A voltmeter is an instrument used for measuring a potential electrical difference (voltage) between two points in an electric circuit.

### **Watt (W)**

A watt is a unit of measurement of power. Wattage is determined by multiplying amperage by voltage.

## 14 Battery Acronyms

<b>AC</b>	Alternating Current	<b>mm</b>	Millimeters
<b>AMP, A</b>	Ampere	<b>MPPT</b>	Maximum Power Point Tracking
<b>AH</b>	Amp-hour	<b>NEC</b>	National Electric Code
<b>AWG</b>	American Wire Gauge	<b>OCV</b>	Open Circuit Voltage
<b>°C</b>	Degrees Celsius	<b>PSOC</b>	Partial State of Charge
<b>C-RATE</b>	Charge Rate	<b>SG</b>	Specific Gravity
<b>DC</b>	Direct Current	<b>SOC</b>	State of Charge
<b>DOD</b>	Depth of Discharge	<b>V</b>	Volt
<b>°F</b>	Degrees Fahrenheit	<b>V/cell</b>	Volt per Cell
<b>ISC</b>	Short Circuit Current	<b>W</b>	Watt
<b>LB</b>	Pounds		
<b>IN</b>	Inches		

# Trojan Battery Company

would like to thank you for selecting the Solar Industrial battery. With over 90 years of experience, Trojan Battery is the world's most trusted name in deep-cycle battery technology backed by our outstanding technical support. We look forward to serving your battery needs.

## **TROJAN BATTERY COMPANY**

12380 Clark Street, Santa Fe Springs, CA 90670 USA

## **TECHNICAL SUPPORT**

Call **800-423-6569**, and **press option 3** or **+1-562-236-3045**  
or Visit [www.trojanbattery.com](http://www.trojanbattery.com)

To determine the model and quantity of Trojan batteries needed for renewable energy or backup power system, visit [www.batterysizingcalculator.com](http://www.batterysizingcalculator.com).

© 2018 Trojan Battery Company. All rights reserved.

This publication is protected by copyright and all rights are reserved. No part of it may be reproduced or transmitted by any means or in any form, without prior consent in writing from Trojan Battery Company.

Trojan Battery Company is not liable for direct, indirect, special, exemplary, incidental or consequential damages that may result from any information provided in or omitted from this manual, under any circumstances.

Trojan Battery Company reserves the right to make adjustments to this manual at any time, without notice or obligation.

Trojan Battery Company, the Trojan Battery Company logo, T2 Technology, Maxguard T2 Separator, Alpha Plus Paste, HydroLink, Plus Series, Polyon, Smart Carbon™, TransPower and OverDrive AGM 31 are either registered trademarks or trademarks of Trojan Battery Company.







BATTERY COMPANY

**Trojan**<sup>®</sup>

*Clean energy for life.*

Trojan batteries are available worldwide through Trojan's Master Distributor Network. We offer outstanding technical support, provided by full-time application engineers.

**trojanbattery.com**

800.423.6569 or + 1.562.236.3000

12380 Clark Street, Santa Fe Springs, CA 90670 • USA

© 2018 Trojan Battery Company, LLC. All rights reserved. Trojan Battery Company is not liable for damages that may result from any information provided in or omitted from this publication, under any circumstances. Trojan Battery Company reserves the right to make adjustments to this publication at any time, without notice or obligation. Please check the Trojan Battery website ([www.trojanbattery.com](http://www.trojanbattery.com)) for the most up-to-date information.

TRJN0169\_SIND\_Users\_Guide\_081418