



Magnum Energy, Inc.
 2211 West Casino Rd.
 Everett, WA 98204
www.magnumenergy.com

Introduction

The BR-DC175 and BR-DC250 are the same DC breakers installed in the MP (Magnum Panel) and MMP (Mini Magnum Panel) system enclosures, and included with the MPX extensions. These breakers function as the inverter's DC disconnect switch and can be used as the battery-to-inverter circuit protection in most installations. These breakers were specifically designed and tested to work with Magnum inverters to provide the delay time needed to minimize nuisance breaker tripping.

Depending on the part number, the circuit breaker is either a 175 amp (PN: BR-DC175) or a 250 amp (PN: BR-DC250), high interruption capacity, magnetic-hydraulic, DC circuit breaker. These breakers have front-accessible connections, each provided with a 3/8-16 captive nut. Each breaker includes two 3/8-16 Hex head bolts with washers, and a back mount kit for installing this breaker inside MP enclosures. This kit consists of two mounting straps and two #10-32 x 3.5" Torx screws to attach the DC breaker to a mounting panel.



CAUTION: These breakers must be mounted in a vertical position to meet the specified trip current and trip delay curve.

Sizes shown in inches (mm)

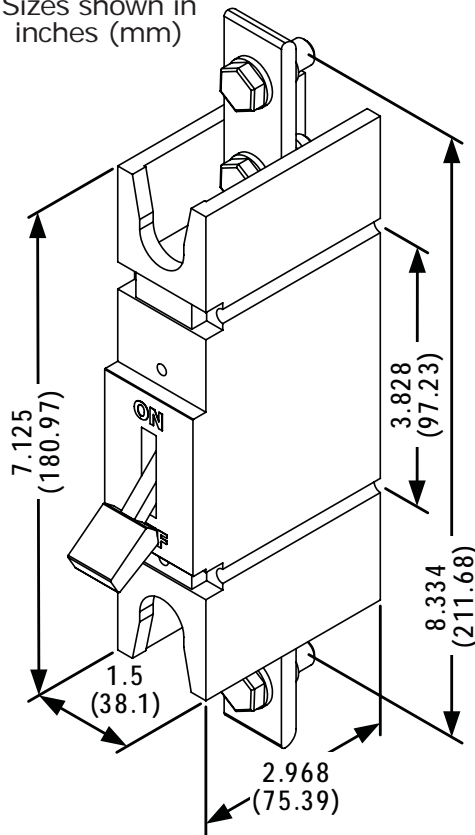

Specifications	
Approvals	<ul style="list-style-type: none"> • UL 489 Listed Branch Circuit-Breaker • CSA Certified C22.2 No. 5
Interrupting Capacity	<ul style="list-style-type: none"> • 10,000 amperes at 160VDC • 65,000 amperes at 65VDC
Trip Time Delay	Customized Delay 53 (DC long delay), constructed to work specifically with Magnum inverters.
Recommended Torque:	220 - 230 inch-pounds (using 3/8" bolts to connect cables - having ring lug terminals - to the 3/8-16 captive nuts on the copper extensions).
Physical:	<ul style="list-style-type: none"> • Weight: ~2.25 lbs. (1020 grams) • Size: See Figure 1 • Terminal connections: Two Front-accessible, tinned-copper extensions, each with a 3/8-16 x 1" bolt and washer screwed into a captive nut.

Figure 1, Physical Dimensions

High Capacity DC Breakers Instruction Sheet



WARNING: During normal operation, the terminals, busbars, and electrical components inside the MP enclosure may be energized - DO NOT TOUCH. Disconnect all power sources before removing the cover. Failure to take action could result in physical harm.

Installation Steps:

1. Remove the breaker front panel cover only after all power has been removed from the Magnum Panel system.

2. Using a T25 screwdriver, remove only the two #10-32 x 3.5" Torx screws that attach the existing DC breaker to the mounting plate and are adjacent to the location that you will add your new DC breaker (see Figure 2).

3. Place the new breaker against the mounting plate adjacent to the existing breaker; with one side of the new DC breaker placed under the side where the two mounting straps are loose.

4. While holding the new breaker in place, attach two new mounting straps over the new DC breaker. Ensure the holes on the two new mounting straps – that are over the existing DC breaker – line up with the holes on the two existing mounting straps (see Figure 3).

5. Insert the two Torx screws that were removed in Step 2 into the aligned holes of the new and existing mounting straps, and tighten to secure the existing DC breaker.

6. Insert two new #10-32 x 3.5" Torx screws into the other side of the new mounting straps and screw down enough to hold the new DC breaker in place. Do not fully tighten the screws, that will be done in Step 7 after being aligned.

Note: The holes in the mounting plate - for the Torx screws that hold the new breaker - are NOT prethreaded. Use a power-driver to screw these self-threading Torx screws (T25 head) into the mounting plate.

7. Check the DC breaker alignment by placing the front panel cover over the DC breakers. If the fit and alignment are correct, tighten all Torx screws to secure the new DC breaker. Note: Be careful not to over-tighten and bend down the tabs on the mounting straps.

The DC breaker is now installed. Connect the inverter and battery cables with the 3/8-16 bolts/washers provided.

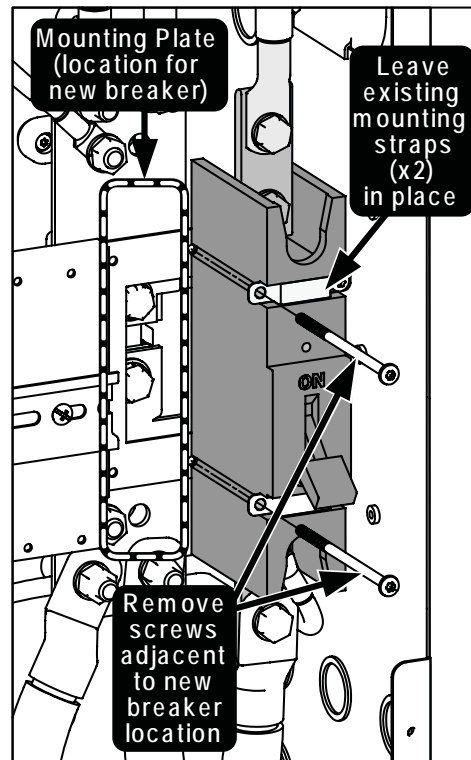

Figure 2, Removing Screws

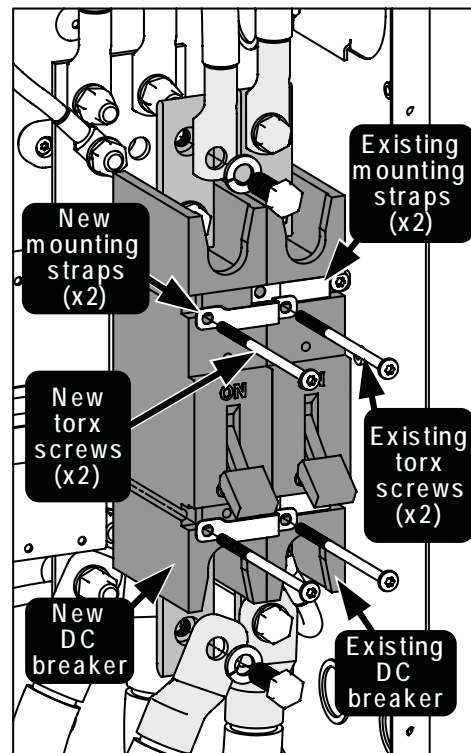

Figure 3, Install New Breaker