



Washer, Electrical Equipment Bond

# WEEB® WASHER

## INSTALLATION INSTRUCTIONS

*For Kinetic Solar*

*K-Rack and Rapid-Rail System Only*

Burndy LLC recommends that the sufficient details of the installation be submitted to the AHJ for approval before any work is started.

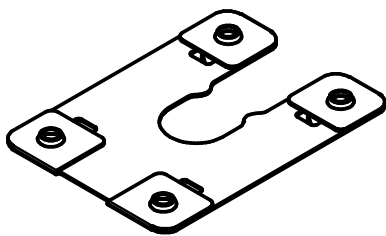

WEEB-KSR

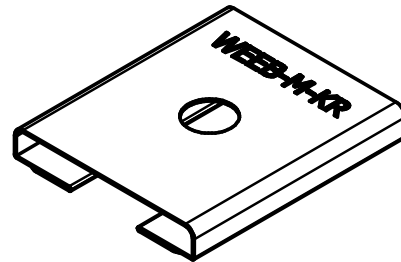

WEEB-M-KR

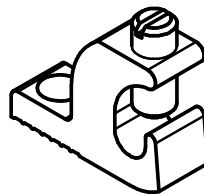

CL501TN



Products are tested to UL 467, CAN/CSA-C22.2 No. 41 US/ Canadian standards for safety grounding and bonding equipment.



Intertek

4004188



# WEEB-M-KR COMPATIBILITY

The WEEB® washer family of products can be used to bond anodized aluminum, galvanized steel, steel and other electrically conductive metal structures. All installations shall be in accordance with NEC requirements in the USA and with CSA C22.1 in Canada. The WEEB® washers are for use with modules that have a maximum fuse rating of less than 25A.

## Standard Top Down Clamps

The WEEB® washers used for bonding the PV modules to the mounting rails are compatible with various cross-sections of module frames. The following are examples of module frames that are compatible. Notice that the WEEB® washer teeth are positioned completely over the edge of the module frame.

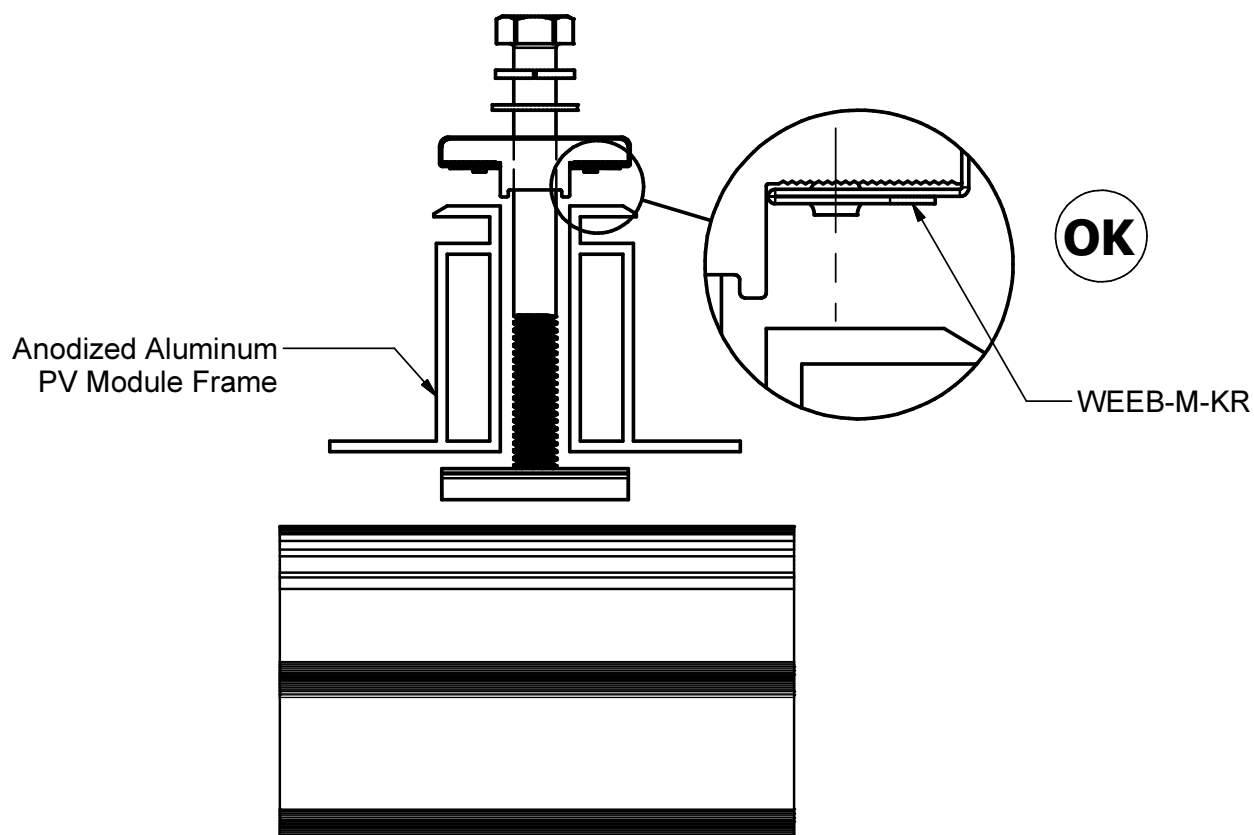

## Note:

**Inspect each module frame used with a WEEB® device to ensure that the bottom mounting face of the frame is flat, and that there are no hindrances to embedding WEEB® washer teeth. Do not use a module with a frame that prevents the WEEB® washer teeth from embedding fully.**

# SYSTEM OVERVIEW

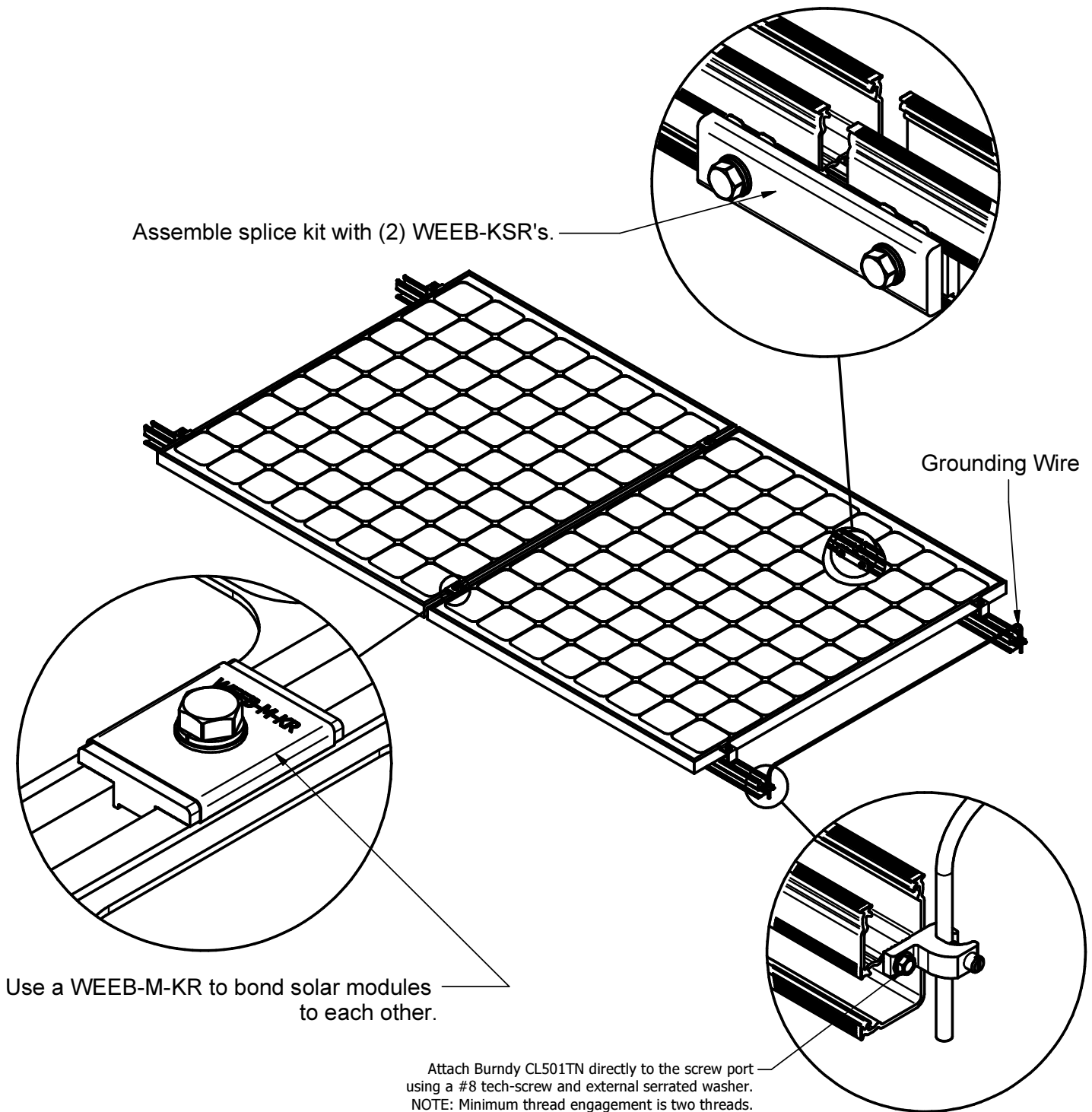

Assemble splice kit with (2) WEEB-KSR's.

Grounding Wire

Use a WEEB-M-KR to bond solar modules to each other.

Attach Burndy CL501TN directly to the screw port using a #8 tech-screw and external serrated washer.  
NOTE: Minimum thread engagement is two threads.

## Important notes:

1. Use general purpose anti-seize compound on fastener threads when installing WEEB® washers.
2. The NEC section 690.43 states “Exposed non-current carrying metal parts of module frames, equipment, and conductor enclosures shall be grounded in accordance with 250.134 or 250.136(A) regardless of voltage”.
3. The WEEB-M-KR is intended for MULTIPLE USE.

# WEEB-M-KR ASSEMBLY

1

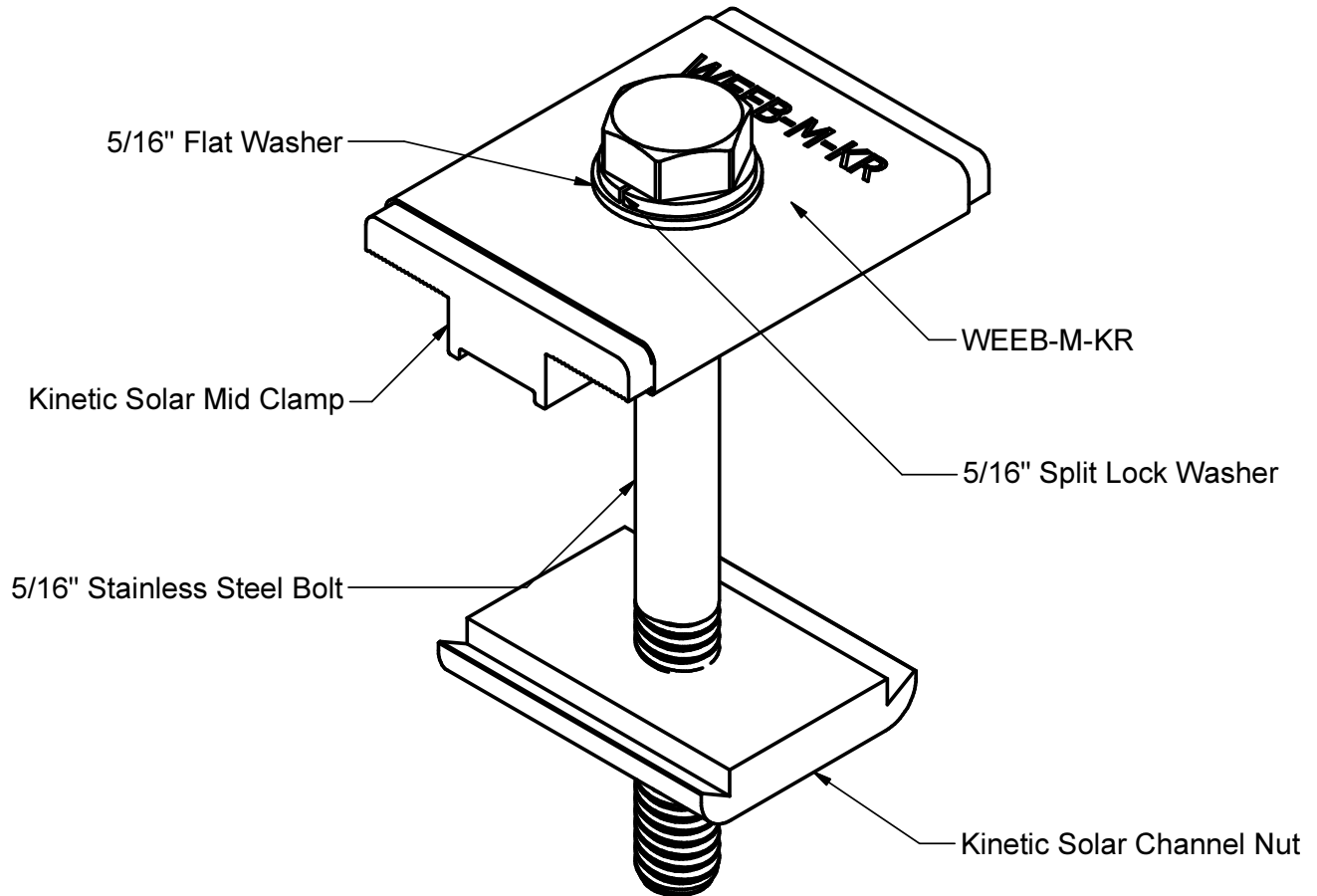

**Pre-assemble WEEB-M-KR to mid-clamp assembly as shown. (WEEB-M-KR comes assembled with the Kinetic mid-clamp in most circumstances.) Pre-assembling WEEB-M-KR to mid-clamp assembly will contain the small individual parts, reducing time required during installation.**

# MID-CLAMP ASSEMBLY

2

Insert the mid-clamp assembly (nut down) into a kinetic rail at approximately a 30 degree angle lift and straighten the mid-clamp assembly. It will pop and click into the rail. Position panels, slide assembly into position and tighten to torque specifications (12ft-lb / 16.3N-m).

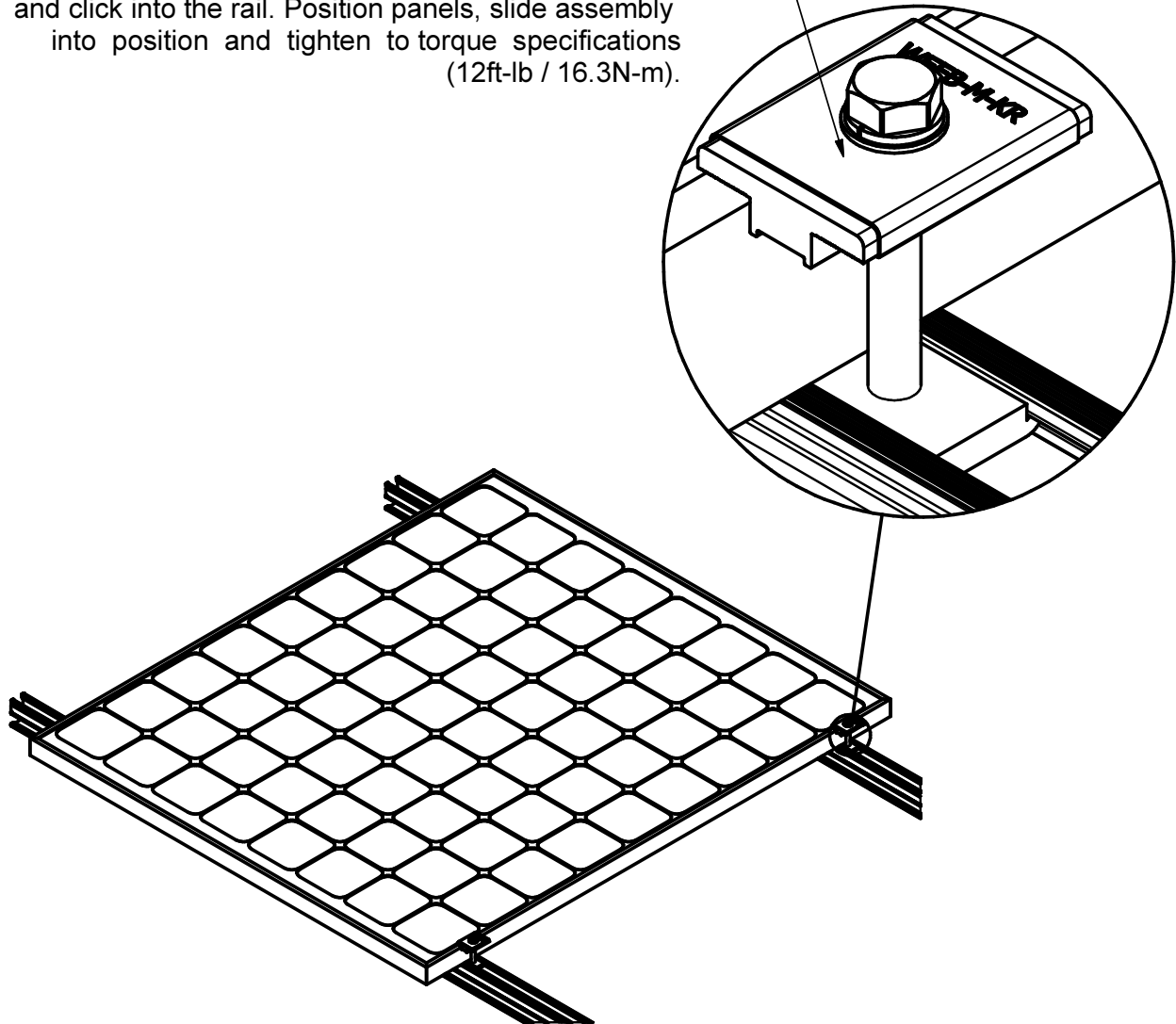

## Important note:

To correctly install WEEB-M-KR, ensure that both sides of the solar modules are completely positioned against the mid-clamp. Refer to WEEB® washer compatibility page for illustrations. Visually check that WEEB® washers are properly positioned.

- 3 When position of solar Modules is finalized, torque fasteners to 12ft-lb / 16.3N-m using general purpose anti-seize compound on threads.

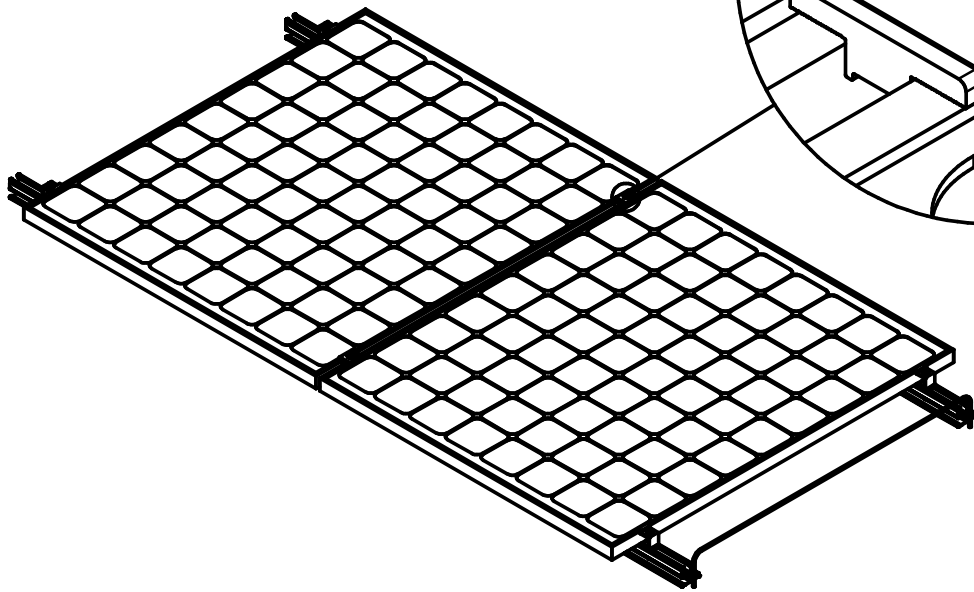

- 4 Assemble the end-clamp to manufacturer's specification. (12ft-lb / 16.3N-m)

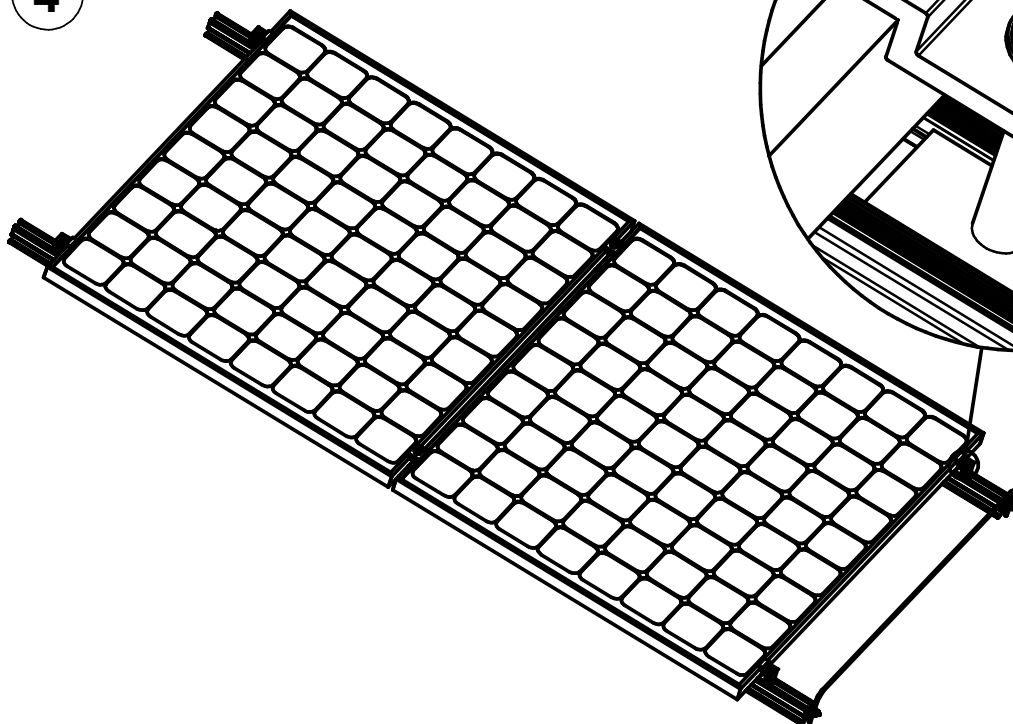

# WEEB-M-KR LAYOUT

5

## EVEN NUMBER OF MODULES IN ROW

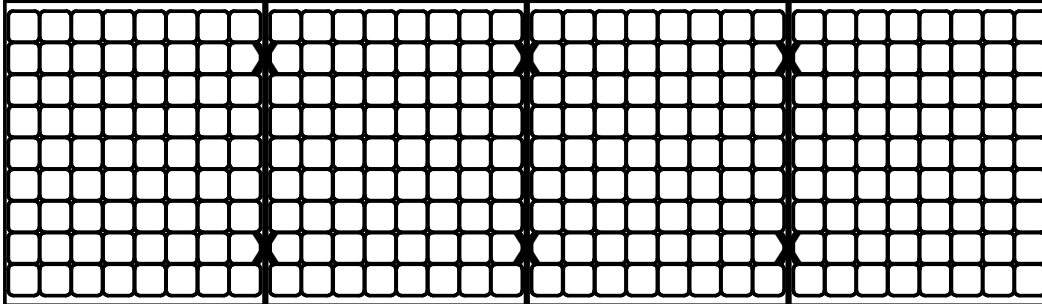

X DENOTES PLACES TO INSTALL WEEB-M-KR

$$\text{WEEB-M-KR NEEDED} = [(C-1) \times R] \times 2 = [(4-1) \times 1] \times 2 = 6$$

## ODD NUMBER OF MODULES IN ROW

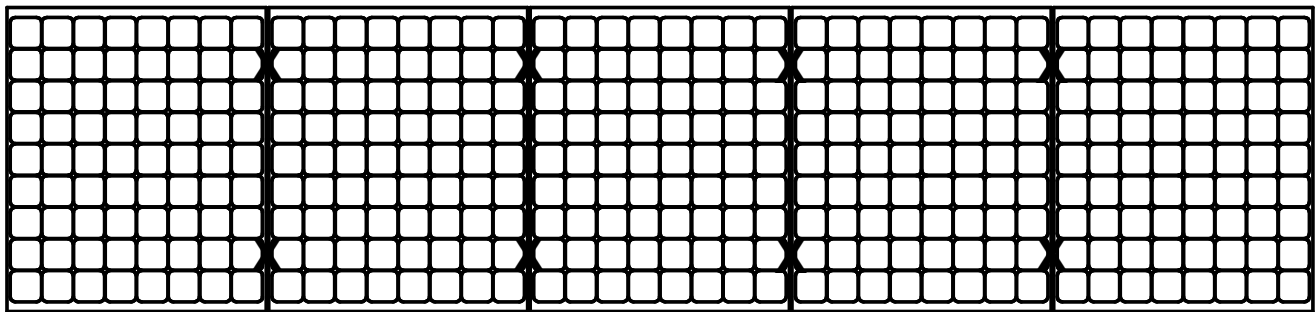

X DENOTES PLACES TO INSTALL WEEB-M-KR

$$\text{WEEB-M-KR NEEDED} = [(C-1) \times R] \times 2 = [(5-1) \times 1] \times 2 = 8$$

The WEEB-M-KR is to be installed at every mid-clamp on the array in order to properly bond the PV modules to each other.

# SPLICE KIT ASSEMBLY

6

Use one (1) **WEEB-KSR** on each side of the splice in order to properly electrically bond the rails.

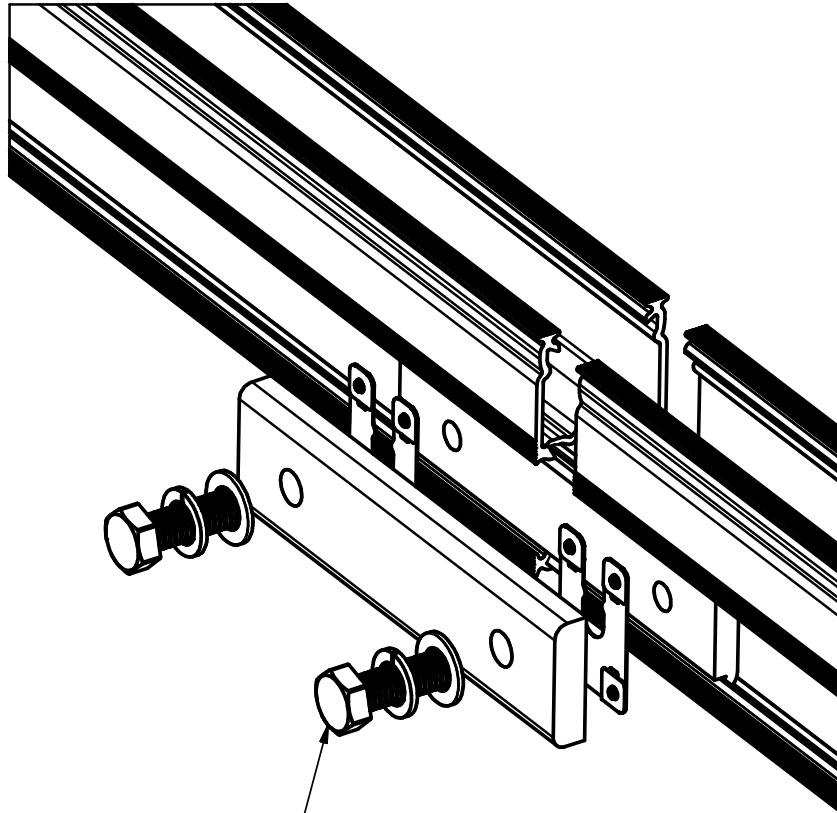

Torque fasteners to  
12 ft-lb / 16.3 N-m using  
general purpose anti-seize  
compound on threads.

**Customer Service Department**  
7 Aviation Park Drive  
Londonderry, NH 03053  
1-800-346-4175  
1-603-647-5299 (International)