

REV	DATE	DES	REVISION DESCRIPTION	CADD	CHK	RWW

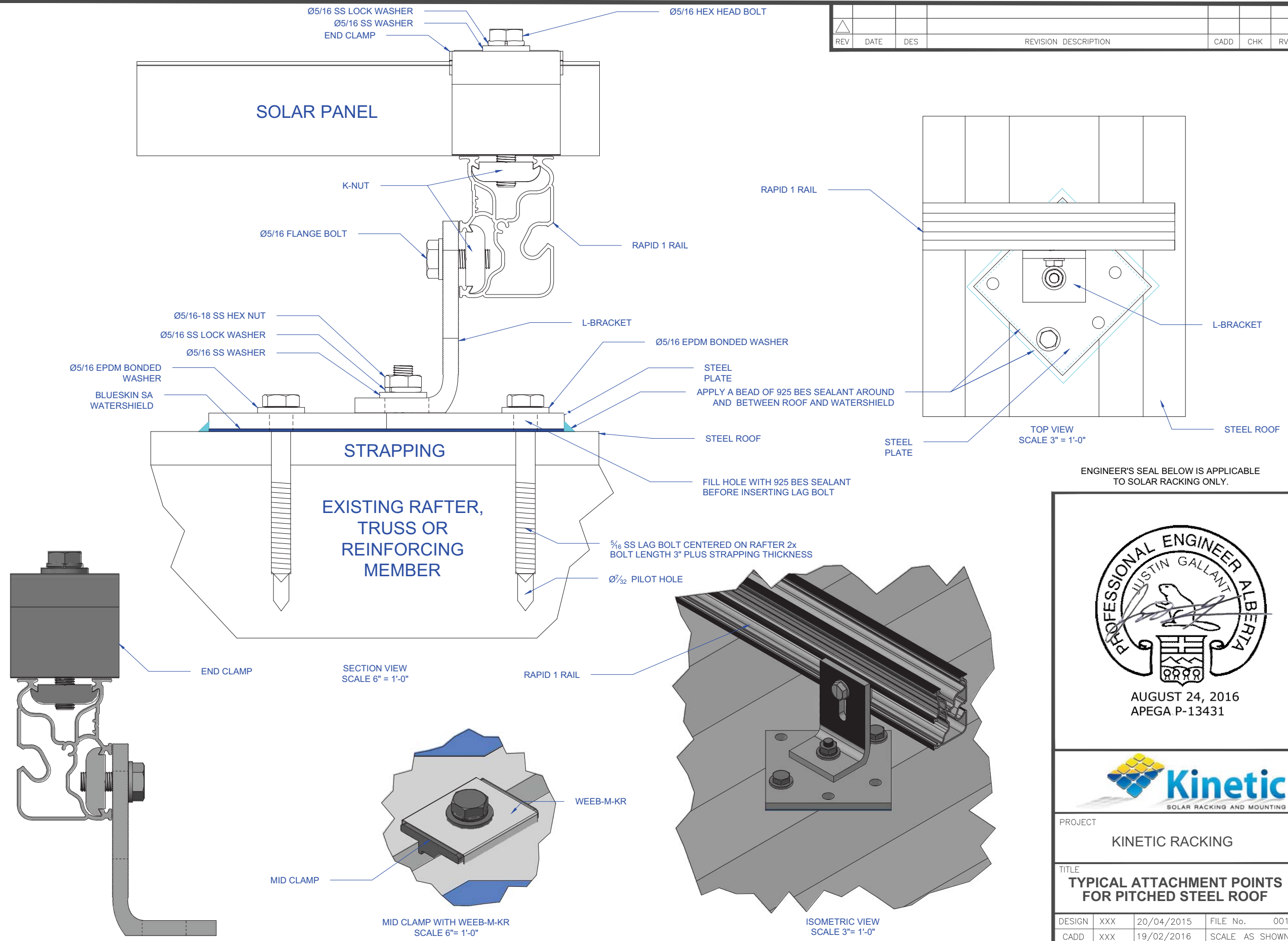

ENGINEER'S SEAL BELOW IS APPLICABLE TO SOLAR RACKING ONLY.

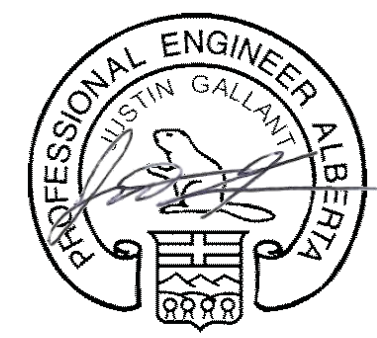

AUGUST 24, 2016
APEGA P-13431



PROJECT
KINETIC RACKING

TITLE
TYPICAL ATTACHMENT POINTS FOR PITCHED STEEL ROOF

DESIGN	XXX	20/04/2015	FILE No.	001
CADD	XXX	19/02/2016	SCALE	AS SHOWN
REVIEW		19/05/2016	REV.	3
PROJECT No.				

DRAWING: MUSTAFA NAZARI